

BA/BB

BUS BAR TAPE

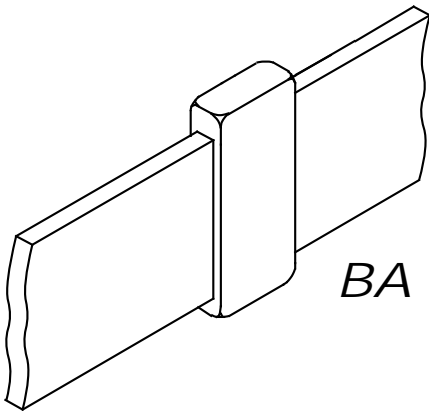

BA

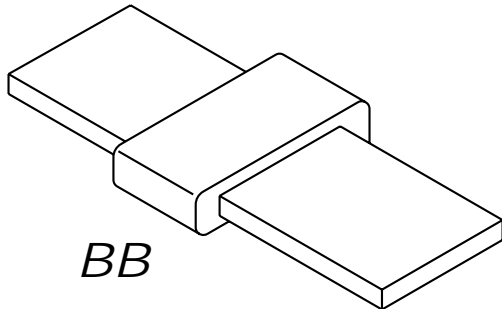

BB

COPPER BUS BAR SPLICE

- TYPE BA - Horizontal, on-edge, bus bar.
- TYPE BB - Horizontal bus bars.
- **Bold letter** in mould part number is the price key.

REQUIRED TOOLS

	European Cat. No.	Search Code
Handle Clamps for C Price Key Moulds	161000	L160
for D Price Key Moulds	161020	L159
Flint Ignitor	165000	T320

SUGGESTED TOOLS

Slag Removal Spade	See CADWELD Classic Table	
Mould Cleaning Brush	165260	120+3/4
Torch Head	140160	T111

BA

BUSBAR SIZE	MOULD PART #	WELD METAL
3X25	BAC C AJ	65
3X50	BAC C AM	90
4X40	BAC E AL	150
4X50	BAC E AM	115
5X40	BAC F AL	150
5X50	BAC F AM	200
6X25	BAC P AJ	115
6X50	BAC P AM	250

BB

BUSBAR SIZE	MOULD PART #	WELD METAL
3X25	BB C AJ	65
3X50	BB C AM	115
4X40	BB E AL	115
4X50	BB D EAM	200
5X40	BB F AL	150
5X50	BB D FAM	200
6X25	BB P AJ	115
6X50	BB D PAM	250

BUSBAR / TAPE KEY

Thickness (mm)	Code	Width (mm)	Code
2	BA	20	H
3	CA	25	J
3,5	DA	30	K
4	EA	35	V
5	FA	40	L
6	PA	50	M
8	GA	60	N
10	HA	80	P
		100	Q