

BUS BAR TAPE

BM/BQ

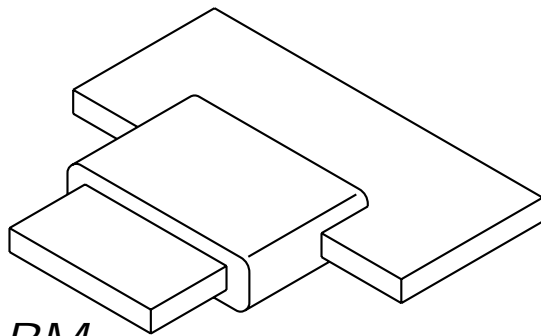

BM

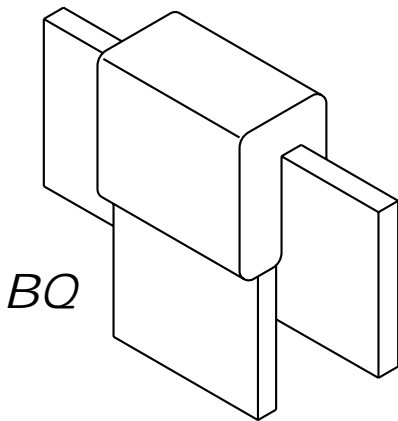

BQ

COPPER BUS BAR

- TYPE BM - Tee tap - horizontal bus bars.
- TYPE BQ - Tee tap down - horizontal, on-edge, bus bars.
- **Bold letter** in mould part number is the price key.

REQUIRED TOOLS

	European Cat. No	Search Code
Handle Clamps for C Price Key Moulds	161000	L160
	for D Price Key Moulds 161020	L159
Flint Ignitor	165000	T320

SUGGESTED TOOLS

Slag Removal Spade	See CADWELD Classic Table	
Mould Cleaning Brush	165260	120+3/4
Torch Head	140160	T111

BM

BUSBAR SIZE	MOULD PART NO.	WELD METAL
3X25	BM C CAJ	65
3X50	BM D CAM	115
4X40	BM E AL	115
4X50	BM D EAM	200
5X40	BM F AL	150
5X50	BM D FAM	200
6X25	BM C PAJ	115
6X50	BM D PAM	250

BQ

BUSBAR SIZE	MOULD PART NO.	WELD METAL
3X25	BQ C CAJCAJ	65
3X50	BQ C CAMCAM	200
4X40	BQ E ALEAL	150
4X50	BQ E AMEAM	250
5X40	BQ F ALFAL	150
5X50	BQ F FAMFAM	200
6X25	BQ C PAJPAJ	150
6X50	BQ C PAMPAM	250

BUSBAR / TAPE KEY

Thickness (mm)	Code	Width (mm)	Code
2	BA	20	H
3	CA	25	J
3,5	DA	30	K
4	EA	35	V
5	FA	40	L
6	PA	50	M
8	GA	60	N
10	HA	80	P
		100	Q