

CADWELD - The Molecular Bond

The MOLECULAR BOND that eliminates connections by forming an electrically perfect bond unaffected by corrosion.

Connections are the weak point of all electrical circuits and especially earthing circuits subjected to ageing and corrosion. The capacity of an earthing circuit to protect the safety of personnel depends on the quality of the connections made.

BS 6651 (1992) STATES

"Any joint other than welded represents a discontinuity in the current conducting system and is susceptible to variation and failure."

THE CADWELD PROCESS

makes it possible to produce copper/copper, copper/aluminium, copper/steel and aluminium/aluminium electrical molecular bonds with no external energy or heat source.

The principle consists of bringing together a welding filler material and ignition agent in a suitable graphite mould. The weld metal composition depends upon the metals to be welded (copper oxide and aluminium for a copper/copper weld).

The reduction of copper oxide by aluminium produces molten copper and aluminium oxide slag at extremely high temperatures. The shape of the mould, its dimensions, and the size of the weld metal, are all dependent on the items to be welded and their size.

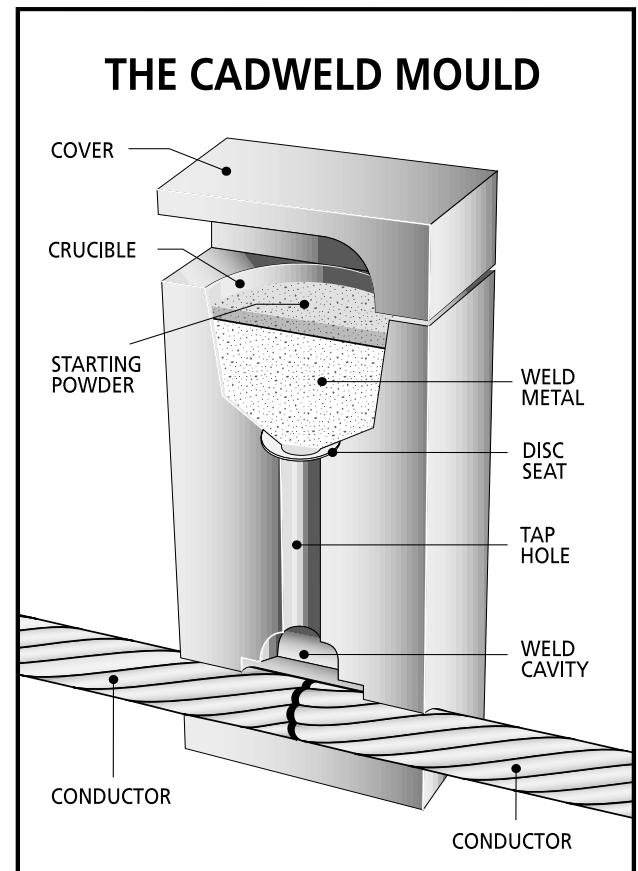

THE BASIC PRINCIPLE

The welding material and starting powder are poured into the mould crucible. They are contained during the reaction, by means of a metal disc seat.

When the reaction is complete, the molten metal is released and flows down the tap hole onto the items to be welded in the weld cavity.

FOUR SIMPLE STEPS

STEP 1. Prepare conductor ends with a wire brush for welding. Place cable ends into open mould.

STEP 2. Close handles to lock mould halves together. Drop metal disk into crucible ensuring it is correctly seated, covering tap hole.

STEP 3. Deposit weld metal into crucible. Tap bottom of container to release starting material. Spread a little starting material on top of mould.

STEP 4. Close the cover and ignite with flint gun. Open the mould after 10 seconds, when metal has solidified.

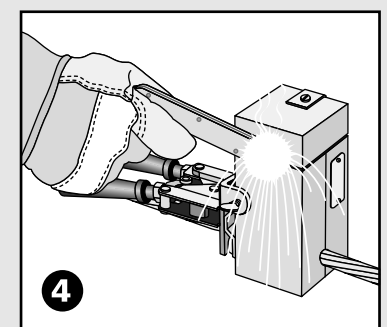
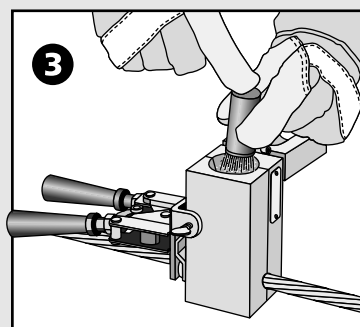
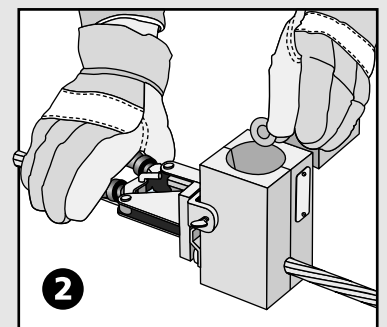
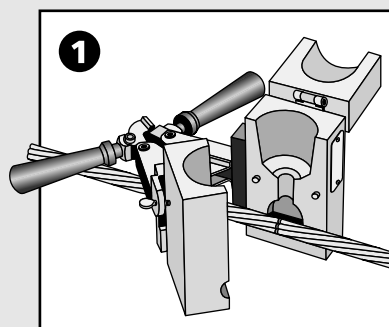

CADWELD - Technical Advantages

THE CADWELD WELD

- Will carry more current than the conductor.
- Will not deteriorate with age.
- Is a molecular bond without any risk of loosening or corrosion.
- Will resist repeated fault currents
- Can be quality controlled simply by visual inspection.

RELIABILITY

As the molecular bond eliminates the concept of surface contact, an electrolyte cannot penetrate between the conductors and cause oxidation and deterioration in the course of time.

Corrosive environments

This reliability is of particular interest for humid or chemical environments or for bonds directly buried in the ground.

ABILITY TO WITHSTAND HIGH CURRENT

The melting temperature of CADWELD filler material is higher than the melting temperature of copper (1082°C). For this reason, in the event of abnormal heating due to a high fault current, the conductor is destroyed before the connection.

CONDUCTIVITY

As a CADWELD weld is a perfect molecular bond, the conductor is not broken and there are no contact surfaces. The integrity of the effective cross section of the conductor is unaltered.

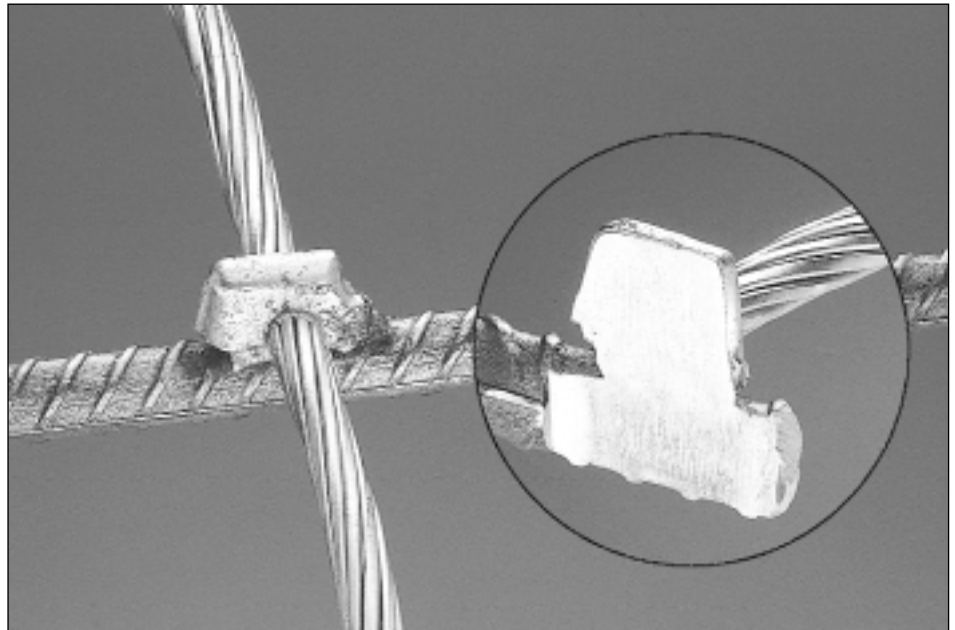

CALCULATED/MEASURED

Standard CADWELD welds have a cross section greater than that of the conductors to be joined, which compensates for the difference in resistivity between the conductor and the weld material. Consequently, under fault conditions the weld will always remain cooler than the conductor.

If special applications do not allow for the required increase in cross section to be employed, the use of the formulae:

$$R = \frac{\rho \times l}{S} \text{ and } V = R \times I$$

will make it possible to define precisely the resistance of the CADWELD weld.

CORROSION TEST

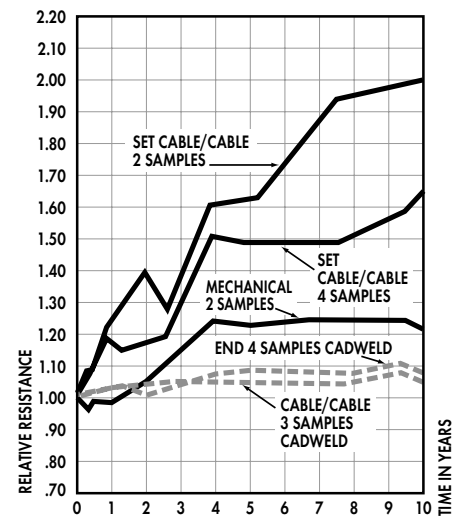

This accelerated ageing test, carried out in a saline atmosphere at a controlled temperature, demonstrates that CADWELD welds retain all their electrical properties during the period of the test whereas the resistance of mechanical connections increase with time and this alters their conductive properties. CADWELD'S fine performance is due to its reliability resulting from the molecular bond.

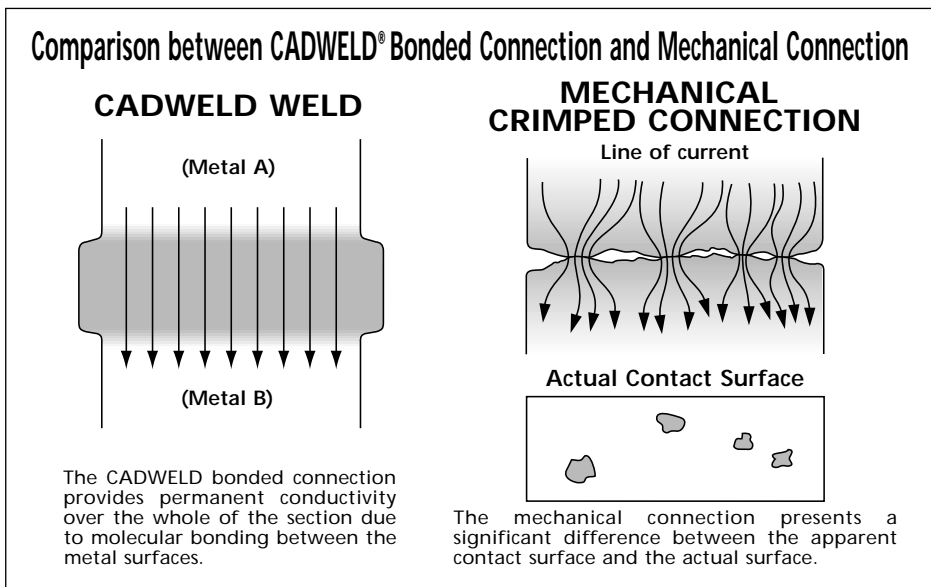

GROUNDING CONNECTION SPECIFICATION

All grounding connections of copper to copper and copper to steel conductors of 2.5sq.mm and larger sized conductors shall be CADWELD® exothermic welded connections. Conductors spliced with a CADWELD exothermic welded connection shall be considered as a continuous conductor, as stated in the notes accompanying NEC 250-81, 250-91, 250-113, 250-115 and IEEE Std 80 - 1986, and IEEE std 837-1989.

HOW TO ORDER CADWELD PRODUCT

This catalog lists popular CADWELD connections. Look in the index that follows for the connection you need. To save time and money, avoid non-catalogue items or “specials” whenever possible.

If you cannot find the connection you need, contact the factory or your local distributor or agent. We have designed over 45,000 connections and “specials” are designed every day.

1. *What connection do you want?*

Available connections are listed in the pictorial index which shows the degree of difficulty in making the connection, and ease of mould cleaning. We strongly recommend that wherever possible you use moulds listed in this catalogue. If your connection is not listed, then consult “*Other Connections*” diagrams for description.

2. *What are the conductor sizes?*

This catalogue covers connections between solid or concentric stranded copper conductors, and bus bars to each other, to lugs, to ground rods, to rebar and to special grounding accessories. For sizes not listed, contact your local CADWELD distributor, agent, or factory.

Note: Other publications describe connections to conductors of copper clad, high voltage copper, aluminum, bus bar, lightning protection cable, steel cable, etc.

3. *You must have the following to make a weld:*

1. Mould to fit your conductors.
2. Weld Metal required by your mould including drop metal disk.
3. Handle Clamps or Frame.
4. Flint Ignitor (included with handle clamps and frames).
5. Lugs, sleeves, packing material listed on the page with the mould.

CADWELD CLASSIC

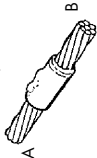
MOULD	EUROPEAN CATALOGUE No.	MOULD TYPE	UNIT WEIGHT kg	DIAMETER		SECTION			WELD METAL	FRAME	TOOLSET	SCRAPER TOOLS	REMARKS
				A mm	B mm	A mm ²	B mm ²	Thick & width					
 SS	221011	SSC-W6	1,370	8,0	8,0	50,26	50,26	45F20	L-160	TS CTS	TP-3B	Solid core cable horizontal splice Solid core cable horizontal splice Multi-strand cable to cable splice Multi-strand cable to cable splice	
	221004	SSC-W8	1,370	10,0	10,0	78,53	78,53	65F20	L-160		TP-3B		
	221006	SSC-Y2	1,370	6,4	6,4	25	25	32F20	L-160		TP-3B		
	221009	SSC-Y3	1,370	7,6	7,6	35	35	32F20	L-160		TP-3B		
	221021	SSC-Y4	1,370	9,0	9,0	50	50	45F20	L-160		TP-3B		
	221013	SSC-Y5	1,750	11,0	11,0	70	70	65F20	L-160		TP-7A		
	221014	SSC-Y6	1,750	12,5	12,5	95	95	90F20	L-160		TP-7A		
	221025	TAC-Y1-Y1	1,370	6,4	6,4	25	25	45F20	L-160		TP-3B		Horizontal T cable to cable connections
	221028	TAC-Y2-Y2	1,370	7,6	7,6	35	35	45F20	L-160		TP-3B		
	222459	TAC-Y3-Y3	1,370	9,0	9,0	50	50	90F20	L-160	TS CTS	TP-7A		
221035	TAC-Y4-Y4	1,370	11,0	11,0	70	70	90F20	L-160		TP-3B			
221075	TAC-Y4-Y2	1,370	11,0	7,6	70	35	65F20	L-160		TP-2A			
222461	TAC-Y5-Y5	1,370	12,5	12,5	95	95	115F20	L-160		TP-7A			
225026	TAC-Y5-Y6	1,570	12,5	14,2	95	120	150F20	L-160		TP-2A			
222463	TAC-Y6-Y6	1,570	14,2	14,2	120	120	150F20	L-160		TP-2A			
221094	TAC-Y6-Y4	1,370	14,2	11,0	120	70	90F20	L-160		TP-7A			
221135	XAC-Y1-Y1	1,370	6,4	6,4	25	25	45F20	L-160		TP-3B	Horizontal X cable to cable connection; (top cable cut)		
221138	XAC-Y2-Y2	1,370	7,6	7,6	35	35	65F20	L-160		TP-3B			
221142	XAC-Y3-Y3	1,370	9,0	9,0	50	50	90F20	L-160	TS CTS	TP-7A			
221148	XAC-Y4-Y4	1,370	11,0	11,0	70	70	115F20	L-160		TP-7A			
221153	XAC-Y5-Y5	1,570	12,5	12,5	95	95	150F20	L-160		TP-2A			
221159	XAC-Y6-Y6	1,750	14,2	14,2	120	120	200F20	L-160		TP-2A			
237901	PGC-Y1-Y1	1,370	6,4	6,4	25	25	45F20	L-160		TP-3B		Parallel horizontal conductors cable to cable	
232556	PGC-Y2-Y2	1,370	7,6	7,6	35	35	65F20	L-160		TP-3B			
232648	PGC-Y3-Y3	1,370	9,0	9,0	50	50	90F20	L-160		TP-7A			
236084	PGC-Y4-Y1	1,370	11,0	6,4	70	25	90F20	L-160		TP-7A			
231342	PGC-Y4-Y4	1,370	11,0	11,0	70	70	115F20	L-160		TP-7A			
223943	PGC-Y5-Y5	1,570	12,5	12,5	95	95	150F20	L-160		TP-2A			
231692	PGC-Y6-Y6	1,570	14,2	14,2	120	120	200F20	L-160		TP-2A			
238978	PCC-E6	1,370	5,2	5,2	21,2	21,2	45F20	L-160		TS CTS	TP-3B		Cable to cable
221609	HAA-Y1	0,310	6,4	6,4	25	25	45F20	M-129		TS CTS	TP-3B		Horizontal concentric copper conductor to flat steel surface or top of horizontal pipe "Sleeve : H 105" Cable to cable through-connections on vertical flat steel surface or cast iron or pipe
221607	HAA-Y2	0,310	7,6	7,6	35	35	45F20	M-129			TP-3B		
221603	HAA-Y3	0,310	9,0	9,0	50	50	45F20	M-129			TP-3B		
222689	HAA-A3	0,310	8,0	8,0	40	40	45F20	M-129			TP-3B		
221466	HAA-Y1-CA	0,310	6,4	6,4	25	25	25F33	M-129			TP-3B		
221534	HAA-Y4	0,450	11,0	11,0	70	70	65F20	M-129			TP-3B		
223044	HBA-B3	0,310	4,9	4,9	14,5	14,5	25XF19	M-129			TP-3B		
228521	VGC-Y1	1,370	6,4	6,4	25	25	45F20	L-160			TP-3B		
224815	VGC-Y2	1,370	7,6	7,6	35	35	45F20	L-160			TP-3B		
222939	VGC-Y3	1,570	9,0	9,0	50	50	90F20	L-160	TS CTS	TP-7A	TP-7A		
228347	VGC-Y4	1,750	11,0	11,0	70	70	115F20	L-160		TP-7A	TP-7A		
223076	VGC-Y5	1,970	12,5	12,5	95	95	150F20	L-160		TP-2A	TP-2A		
223609	VGC-Y6	1,970	14,2	14,2	120	120	150F20	L-160		TP-2A	TP-2A		

CADWELD CLASSIC

MOULD	EUROPEAN CATALOGUE No.	MOULD TYPE	UNIT WEIGHT kg	DIAMETER		SECTION			WELD METAL	FRAME	TOOLSET	SCRAPER TOOLS	REMARKS
				A mm	B mm	A mm ²	B mm ²	Thick & width					
	234429	BMZBAK	0,580			60	60	2 x 30	L-161	TS CTS	TS-5B	Tape	
	234426	BMZCAJ	0,580			75	75	3 x 25	L-161		TP-5B		
	224123	G-BMZDAJ	0,580			87,5	87,5	3,5 x 25	L-161		TS-5B		
	225788	EBZBAK	0,870			60	60	2 x 30	L-161	TS CTS	TS-5B	Tape	
	234991	EBZCAJ	0,580			75	75	3 x 25	L-161		TP-5B		
	223432	G-EBZDAV	0,580			87,5	87,5	3,5 x 35	L-161		TS-5B	Tape	
	232003	CFZBAK	0,520			60	60	2 x 30	L-161	TS CTS	TP-5B		
	233366	CFZCAJ				75	75	3 x 25	L-161			Tape	
	225147	G-CFZDAJ				87,5	87,5	3,5 x 25	L-161				
	238039	B-GRC-P143-Y3	1,750	14,2	9,0	160	50		L-160	TS CTS	TP-7A	Single cable to top of ground rod	
	225814	GTC-P143-Y3	1,750	14,2	9,0	160	50		L-160		TP-7A		
	232996	GTC-P143-Y4	1,570	14,2	11,0	160	70		L-160		TP-7A	Cable to ground rod	
	223520	GTC-P143-Y5	1,570	14,2	12,5	160	95		L-160		TP-7A		
	226083	GTC-P172-Y3	1,570	17,3	9,0	232	50		L-160	TS CTS	TP-7A		
	227687	GTC-P172-Y4	1,570	17,3	11,0	232	70		L-160		TP-7A		
	227549	GTC-P172-Y5	1,570	17,3	12,5	232	95		L-160		TP-7A		
	223138	GTC-P190-2G	1,570	19	10,7	284	66,5		L-160		TP-7A		
	232537	GEC-P128	1,750	12,7	12,7	126	126		L-160	TS CTS	TP-7A		Horizontal ground rod to ground rod splice
237727	GEC-P143	1,970	14,2	14,2	158	158		L-160	TS CTS	TP-2A			
	238544	GFC-P143-Y3	1,750	14,2	9,0	160	50		L-160	TS CTS	TP-7A	Horizontal cable to ground rod splice	
	238556	GFC-P165-G2B	1,750	16,3	9,5	214	50		L-160	TS CTS	TP-7A		
	224800	LAC-Y1-BAH	1,370	6,4		14	40	2 x 20	L-160	TS CTS	TP-3B	Cable to Cu lug or tape Cable to Cu lug or tape Cable to Cu lug or tape Cable to Cu lug or tape Cable to Cu lug or tape Cable to Cu lug or tape Cable to Cu lug or tape	
	222501	LAC-Y1-CAJ	1,370	6,4		25	75	3 x 25	L-160	TS CTS	TP-3B		
	224150	LAC-Y2-BAH	1,370	7,6		35	40	2 x 20	L-160	TS CTS	TP-3B		
	221443	LAC-Y2-CAJ	1,370	7,6		35	75	3 x 25	L-160	TS CTS	TP-3B		
	239534	LAC-Y3-BAH	1,370	9,0		50	40	2 x 20	L-160	TS CTS	TP-3B		
	222122	LAC-Y3-BAJ	1,370	9,0		50	50	2 x 25	L-160	TS CTS	TP-3B		
	221455	LAC-Y3-CAJ	1,370	9,0		50	75	3 x 25	L-160	TS CTS	TP-3B		
233795	LAC-L9-EAKA	1,750	10,0		60	120	4 x 30	L-160	TS CTS	TP-7A			

Lug details for LA connections

Remarks	Prefix Code	LUG	Article No	LUG	Article No
Cable to pre-drilled Cu Lug	LAC-Y1-	KA-101	183000	KOF-101	183180
	LAC-Y1-	KA-103	183020	KOF-103	183200
	LAC-Y2-	KA-101	183000	KOF-101	183180
	LAC-Y2-	KA-103	183020	KOF-103	183200
	LAC-Y3-	KA-101	183000	KOF-101	183180
	LAC-Y3-	KA-102	183010	KOF-102	183190
(See page 46)	LAC-Y3-	KA-103	183020	KOF-103	183200

TECHNICAL INFORMATION

GROUNDING SYSTEM – CONDUCTORS AND CONNECTORS

The grounding conductor size is based on the maximum magnitude and duration of available fault current, and on the type of connections being used in the grounding system.

IEEE Std. 80-1986, Guide for Safety in Substation Grounding, the accepted industry standard, uses a fusing formula as the basis for selecting minimum conductor size to avoid fusing (melting) under fault conditions.

This formula can be simplified to the following:

$$A = K \cdot I \sqrt{S}$$

Where: **A** = Conductor size in mm²
K = Constant from the following table
I = RMS fault current in amperes
S = Fault time in seconds
 Based on the standard ambient temperature of 40C.

MAX TEMP	CONSTANT K FOR ABOVE FORMULA		
	COPPER S.D.	COPPERWELD DSA 40%	COPPERWELD DSA 30%
1083 C	3.55	5.30	6.10
450 C	4.65	6.96	8.04
350 C	5.12	7.67	8.85
250 C	5.90	8.85	10.22

The temperatures listed above for each material are specified in IEEE Std. 80-1986 to be used for different types of connecting means;

- Pressure type connectors 250 to 350 C*
- Brazed connections 450 C
- Exothermic welded connections 1083 C

*except those that have been tested to and passed the requirements of IEEE Std. 837-1989.

RELATIVE SIZES

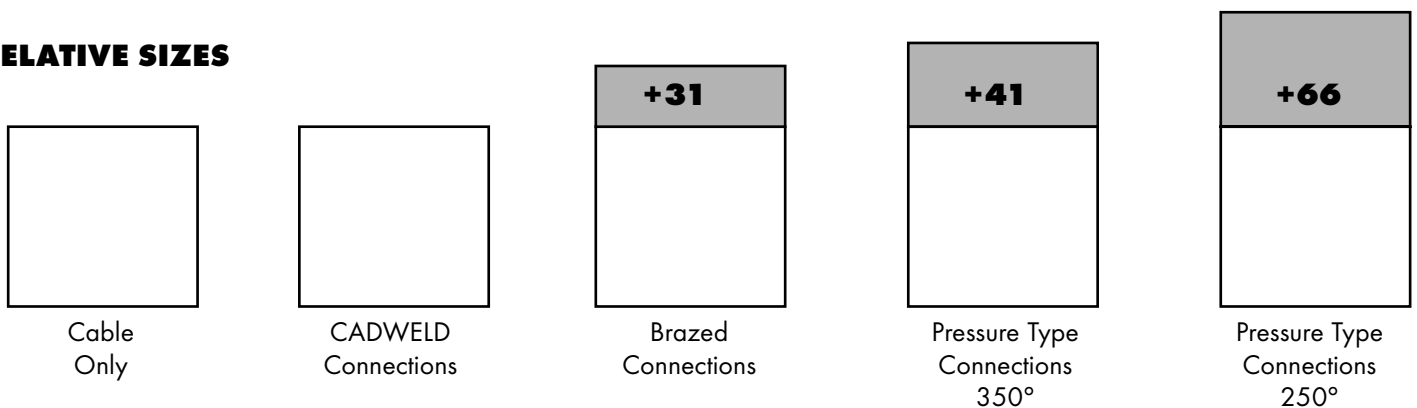

EXAMPLE – 25,000 Ampere, 2 second fault:

CONNECTION TYPE	CONDUCTOR SIZE
CADWELD Electrical126mm ² - use 150mm ²
Brazed164mm ² - use 185mm ²
Pressure Type (at 350 C)181mm ² - use 185mm ²
Pressure Type (at 250 C)209mm ² - use 240mm ²

THE CADWELD MOULD NUMBERING SYSTEM

The CADWELD® Mould Part Number gives, in code, the complete information of the mould - type of connection, mould price key, and conductor size(s).

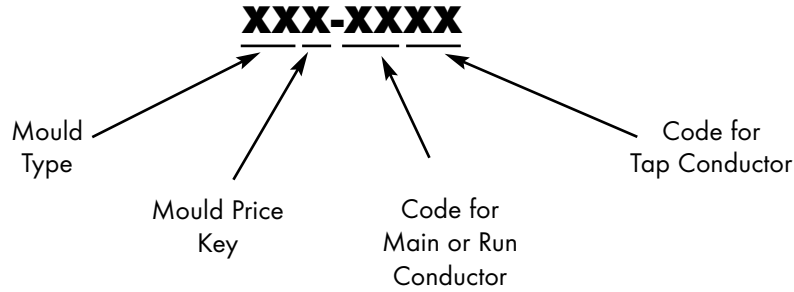

EXAMPLES

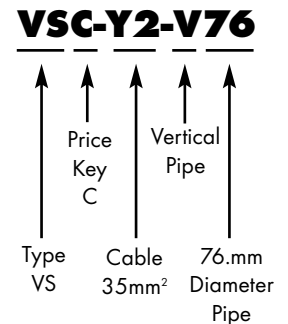
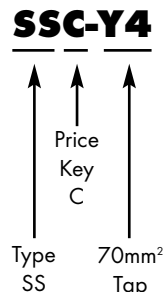
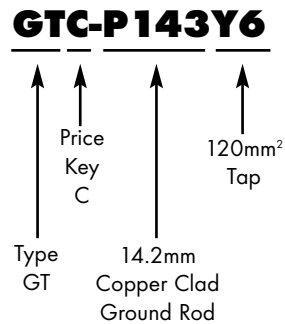
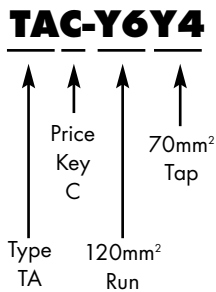

COMMON REFERENCE FOR CABLE DIAMETERS

Nominal Area (mm ²)	Concentric Cable		
	Strand	Diameter Range (mm)	Cable Size Code
6	7/1.04	3,12	A7
10	7/1.45	4,12	W2
10	7/1.35	4,05	W2
16	7/1.70	5,10	W3
16	7/1.68	5,04	W3
25	7/2.14	6,42	Y1
25	19/1.30	6,75 - 6,50	Y1
35	7/2.53	7,60 - 6,42	Y2
35	19/1.53	6,75	Y2
50	19/1.78	8,90	Y3
50	19/1.83	9,20 - 9,14	Y3
70	19/2.14	10,70	Y4
70	19/2.17	10,90 - 10,85	Y4
95	37/1.78	12,46	Y5
95	37/1.81	12,7 - 12,67	Y5
120	37/2.03	14,21	Y6
120	19/2.84	14,20	Y6

For other cable sizes or different stranding, please contact your local CADWELD® distributor, agent or factory.

MATERIALS, TOOLS & ACCESSORIES

CADWELD MOULDS

A semi-permanent graphite mould is used for making most CADWELD connections. The mould controls the direction and speed of the molten CADWELD weld metal flow and its final shape. The graphite used in a CADWELD mould is a high temperature type that lasts for an average of 50 or more CADWELD connections under normal usage.

Pictured right: Typical CADWELD mould with handle clamps (L-160)

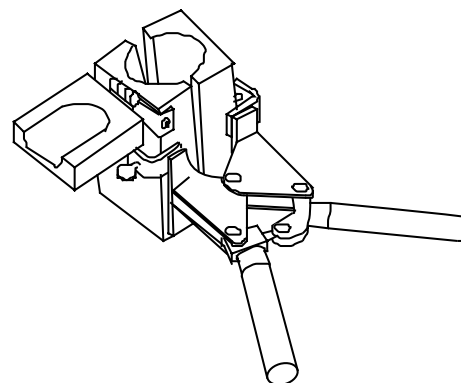

MOULD FASTENING AND MOUNTING

Specialised Handle Clamps and Frames are used on most CADWELD® graphite moulds.

CADWELD® Handle Clamps

European Cat. No.	Ref Code	Description	Max Width Mould (mm)	Unit Weight (kg)
161000	L-160	Small Standard Handle Clamp for "C", "E" & "R" Price Moulds	79	1,23
161020	L-159	Large Standard Handle Clamp for "D", "F" & "J" Price Moulds	102	1,39
161010	L-161	Small Handle Clamps (Europe Only)	-	0,380

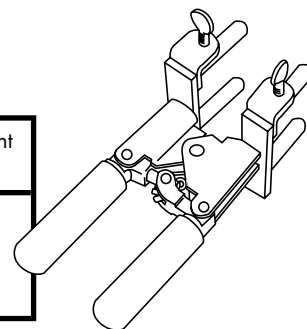

CADWELD® Vertical Surface Mould Support

The CADWELD® Mould can be securely held to a vertical "H" column or angle by using a Vertical Surface Mould Support.

- Easily attached to an existing L159 or L160 Standard Handle Clamp.
- Fits steel up to 25mm thickness for VB, VG, VN and VS moulds.
- Fits steel up to 19mm thickness for VF moulds.

European Cat. No.	Ref Code	Description	Max Width Mould (mm)	Unit Weight (kg)
161740	B-134	Vertical Surface Mould Support for "C", "E" & "R" Price Moulds	79	0,36
161780	B-135	Vertical Surface Mould Support for "D", "F" & "J" Price Moulds	102	0,42

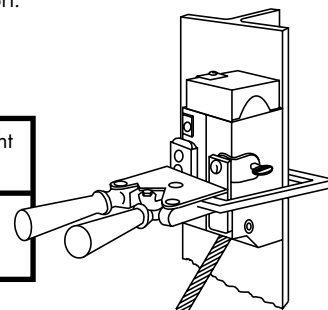

CADWELD® Pipe Chain Support Clamps and Pipe Frames

The CADWELD® Mould can be securely held to pipes of various diameters using a Chain Support Clamp assembly.

Clamps are equipped with 500mm length of chain which will firmly hold to a pipe of up to 100mm diameter. Chain extensions are available.

European Cat. No.	Ref Code	Description	Pipe	Unit Weight (kg)
161090	L-161A	European Pipe Chain Support Clamp	Vertical	1,01
161060	B-160V	Chain Support Clamp for "C" & "R" Price Moulds (VS, VF, VB & VV)	Vertical	1,80
Asia / Aust.	B-160VT	Chain Support Clamp for "C" & "R" Price Moulds (VT connections)	Vertical	1,75
Asia / Aust.	B-160H	Chain Support Clamp for "C" & "R" Price Moulds (HA, HS, HC, & HT)	Horizontal	1,91
Asia / Aust.	B-159V	Chain Support Clamp for "D" & "F" Price Moulds (VS, VF, VB & VV)	Vertical	2,15
Asia / Aust.	B-159VT	Chain Support Clamp for "D" & "F" Price Moulds (VT connections)	Vertical	2,10
Asia / Aust.	B-159H	Chain Support Clamp for "D" & "F" Price Moulds (HA, HS, HC, & HT)	Horizontal	2,20
	B-158	Extra 500mm chain for 250mm Pipe	N/A	1,25
161030	M-129	Vertical Clamp (HA connections)		0,315
161040	M-125	Horizontal Clamp		0,200

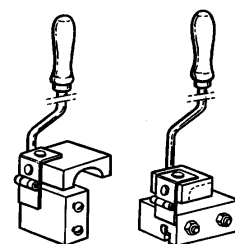
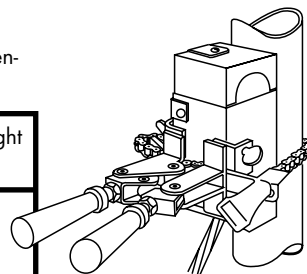

MATERIALS, TOOLS & ACCESSORIES

CADWELD WELD METAL

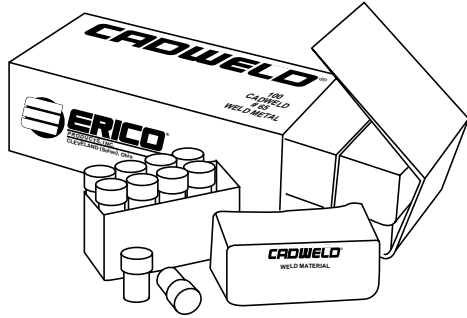

- CADWELD® Weld Metal is a mixture of copper oxide and aluminium, packaged by size in individual plastic tubes.
- Each tube contains the starting material at the bottom of the tube, with the Weld Metal on the top.
- These containers are packaged in plastic boxes with the corresponding metal disks. Each weld uses one disk.
- These materials are not explosive and not subject to spontaneous ignition.
- There are three Weld Metal mixtures used for grounding connections.

F20 or Standard Weld Metal (Grey or clear natural cap)

- Used for all grounding connections except cast iron or load bearing rail
- Copper / copper
- Copper / steel
- Steel / steel

European Cat. No.	Reference Code		Disk (supplied with Weld Metal)		Unit Weight (kg)
			European Code	Diam. (mm)	
163000	25 F20	20	141154	19	0,025
163010	32 F20	20	141154	19	0,032
163020	45 F20	20	141154	19	0,045
163030	65 F20	20	141154	19	0,065
163040	90 F20	10	141156	25	0,090
163050	115 F20	10	141156	25	0,115
163060	150 F20	10	141157	38	0,150
163070	200 F20	10	141157	38	0,200
163080	250 F20	10	141157	38	0,250

F33 (Green cap)

- Used for all cathodic connections
- Steel pipe

European Cat. No.	Reference Code		Disk (supplied with Weld Metal)		Unit Weight (kg)
			European Code	Diam. (mm)	
163200	15 F33	20	141154	19	0,015
163210	25 F33	20	141154	19	0,025
163220	32 F33	20	141154	19	0,032
163230	45 F33	20	141154	19	0,045
163240	65 F33	20	141154	19	0,065
163250	90 F33	10	141156	25	0,090
163260	115 F33	10	141156	25	0,115
163270	150 F33	10	141157	38	0,150

XF19 (Orange cap)

- Used for connections to cast iron (HB etc)
- Cathodic protection

European Cat. No.	Reference Code		Disk (supplied with Weld Metal)		Unit Weight (kg)
			European Code	Diam. (mm)	
163280	25 XF19	20	141154	19	0,025
163290	32 XF19	20	141154	19	0,032
163300	45 XF19	20	141154	19	0,045
163310	65 XF19	20	141154	19	0,065
163320	90 XF19	10	141156	25	0,090
163330	115 XF19	10	141156	25	0,115

MATERIALS, TOOLS & ACCESSORIES

TOOL KITS

Standard Tool Set (Europe)

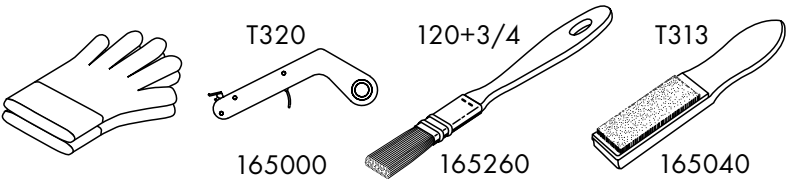

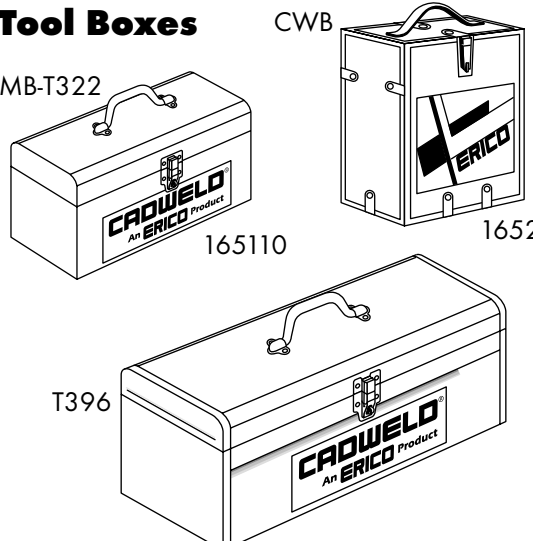

Item No.	Reference Code	Standard Bundle	Unit Weight kg
197290	TS CST	1	0,450

Tool Boxes

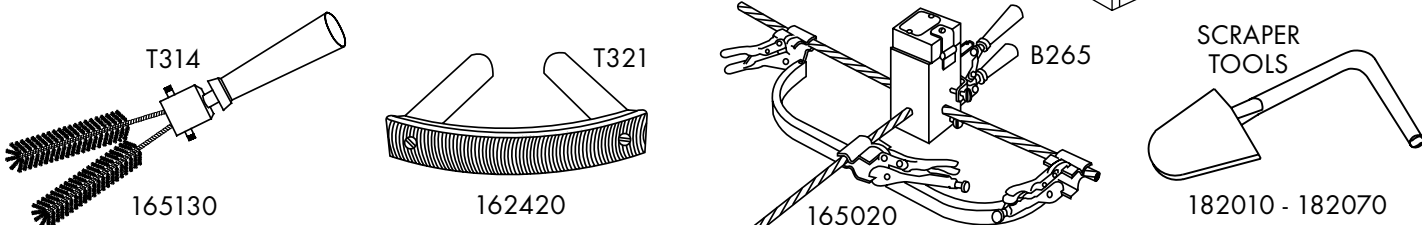

SCRAPER TOOLS & ACCESSORIES



European Cat No.	Reference Code	Description		Unit Weight (kg)
165110	CMB-T322	Tool Carry Box 450x160x250	1	2,540
165210	CWB	Tool Carry Box 390x190x400	1	3,695
Asia/Australia	T396	Tool Carry Box 556x220x220	1	3,750
165000	T320	Flint Ignitor	1	0,090
165010	T320A	Spare Flints	10	0,015
165260	120+3/4	Mould Cleaning Soft Brush	1	0,280
Asia/Australia	T394	Mould Cleaning Soft Brush	1	0,260
165040	T313	Card Cloth Cable Cleaning Brush	1	0,070
165130	T314	Cable Cleaning Brush	1	0,280
165270	T314A	Spare Heads for Cable Brush	2	0,070
162420	T321	Rasp	1	0,250
165020	B265	Cable Clamp	1	3,480
182030	TP2A	Mould Scraper Tool	1	0,144
182040	TP4A	Mould Scraper Tool	1	0,172
182010	TP5A	Mould Scraper Tool	1	0,116
182050	TP6A	Mould Scraper Tool	1	0,126
182020	TP7A	Mould Scraper Tool	1	0,132
182060	TP-3B	Mould Scraper Tool	1	0,045
182070	TP-5B	Mould Scraper Tool	1	0,060
165080	Solvent Marine	Solvent Marine	1	0,700
165280	T403	CADWELD Mould Sealer	1	0,910
165070	T358	CADWELD Regalv Coating	1	0,350
140160	Europe only	Blowlamp Soudo 360	1	0,260
140180	Europe only	Cartridge for Blowlamp Soudo 360	1	0,100
Asia / Australia	T111	IPI Surefire Torch Head	1	

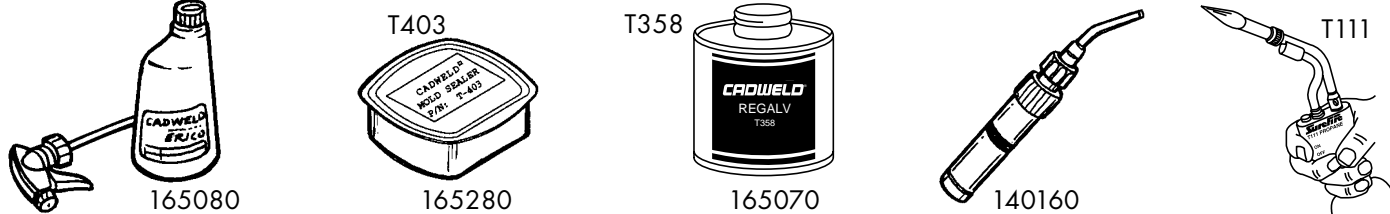

MATERIALS, TOOLS & ACCESSORIES

CADWELD® CABLE SLEEVES

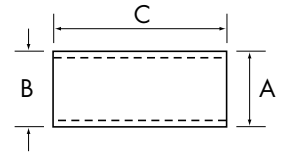
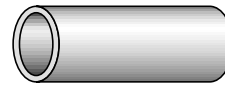

STRAIGHT

European Cat No.	Reference Code	A (mm)	B (mm)	C (mm)		Bundle Weight (kg)
180140	H101	8,0	6,0	26	50	0,25
180170	H102	6,4	4,3	25	50	0,20
180180	H103	7,7	5,3	25	50	0,30
180190	H104	19,0	17,0	26	50	0,675
180230	H105	5,0	3,0	23,5	50	0,15
180690	H107	11,0	9,0	26	50	0,40
180010	H108	20,0	18,0	26	50	0,70
180020	H109	14,0	12,0	26	50	0,50
180350	H113	10,0	8,0	26	50	0,35
180700	H115	6,35	4,83	25	50	0,15
180430	H117	9,0	7,0	25	50	0,30

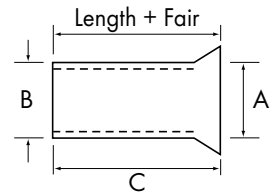
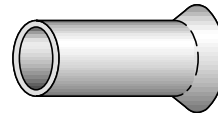

FLARED

European Cat No.	Reference Code	A (mm)	B (mm)	C (mm)	Length + Flair		Bundle Weight (kg)
180150	H101F	8,0	6,0	25	26	50	0,25
180390	H102F	6,4	4,3	25	26	50	0,20
180380	H103F	7,7	5,3	25	26	50	0,30
180200	H104F	19,0	17,0	25	26	50	0,65
180250	H106F	17,0	15,0	25	26	50	0,45
180270	H107F	11,0	9,0	25	26	50	0,40
180280	H108F	20,0	18,0	25	26	50	0,70
180300	H109F	14,0	12,0	25	26	50	0,50
180320	H111F	15,0	13,0	25	26	50	0,55
180340	H112F	12,0	10,0	25	26	50	0,40
180360	H113F	10,0	8,0	25	26	50	0,35
180040	H114F	25,0	21,0	25	26	50	0,41
180740	H116F	13,0	11,5	25	26	50	0,35
180080	H117F	9,0	7,0	25	26	50	0,30
180220	H104BF	19,0	17,0	34	35	50	0,90
180260	H106AF	17,0	15,0	34	35	50	0,60
180310	H109AF	14,0	12,0	34	35	50	0,65
180330	H111AF	15,0	13,0	34	35	50	0,70
180030	H113AF	10,0	8,0	34	35	50	0,45

CADWELD® WRAP SLEEVE

European Cat No.	Reference Code	Standard Bundle	Bundle Weight (kg)
165610	B-140-A-EE	25	0,250

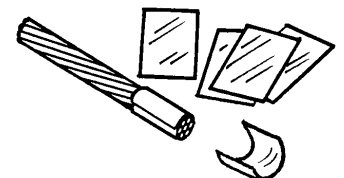

CADWELD® Grounding Connection Kits

ERICO® can provide customised connection kits with tools and weld moulds in full preparation for “work on the job”.

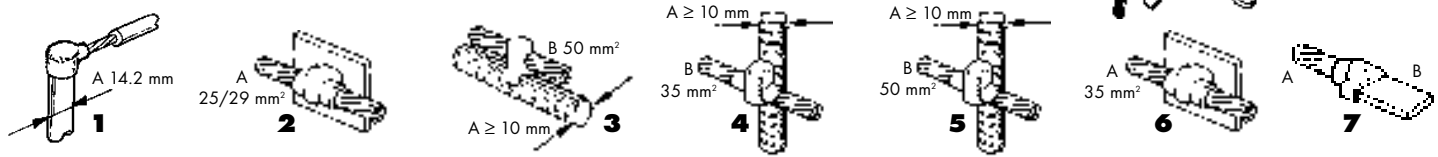

Sample Application	Connection Illustration	Reference Code	European Item No.	Typical No. of Welds per Kit	Unit Weight (kg)
Compact Kit	1	GR-P143-25	169310	20	2,110
Compact Kit	2	VG-25/29	168090	60	2,265
Maxi-Kit Rebar	3	RT-50-Z-10	168850	60	8,695
Maxi-Kit Rebar	4	RC-35-Z-10	168890	60	6,000
Maxi-Kit Rebar	5	RC-50-Z-10	168910	60	8,225
Maxi-Kit VG-35	6	VG-35	168450	60	6,785
Maxi-Kit LA-Y2	7	LA-Y2-FAK	169600	100	16,750

TELECOMMUNICATIONS APPLICATIONS (France Telecom)



1. Galvanised 7mm Ø Cable (7 wisps) to 20mm Ø Galvanised Ground Rod

European Cat No	Contents		Unit Weight (kg)
546030	GTZ-P205-SS A2 Graphite Mould L161 Handle Clamps Positioning Tool for Ground Rod Graphite Plate Rod Driving Head 20,5 mm Ø TS-CST Tool Set Cover Adapted 65F20 W/M + gap rod CMB-T322 Metal Case	1 1 1 1 1 1 1 20 1	5.5 kg

2. Connections of 2 / 4 Galvanised Cables (Ø = 5 or 7mm)

European Cat No	Contents		Unit Weight (kg)
546000	EF-XZZ-FT graphite Mould L161 Handle Clamps TS-CST Tool Set Cover Adapted 65F20 WIM + gap rod CMB-T322 Metal Case	1 1 1 1 20 1	4.7 kg

3. Connections of 4 x 5mm Ø (4 wisp) Galvanised Cables

European Cat No	Contents		Unit Weight (kg)
546060	PTZ-Y1 FT Graphite Mould L161 Handle Clamps TS-CST Tool Set Cover Adapted 32F20 WIM (546100) CMB-T322 Metal Case	1 1 1 1 20 1	4.7 kg

CADWELD® Cathodic Protection Connection Kits

(See Catalogue CA-1A)

- CADWELD connections are the accepted method of attaching cathodic protection leads to pipes (steel and cast iron) tanks and structures.
- CADWELD connections weld conductors to the object to be protected thus preventing galvanic corrosion occurring at the interface. (With mechanical connections, surface contacts are present, and can corrode, resulting in an ineffective current path.)
- CADWELD connections for cathodic protection use a special alloy to provide minimum heat effect on the steel, especially important on thin wall, high stress pipes.
 - F-33 alloy (Green Caps) is used for connections of cable to cable and cable to steel or stainless steel pipe.
 - XF-19 (Orange Caps) is used for all connections to cast iron.
 - Weld metal packs are available as consumables.

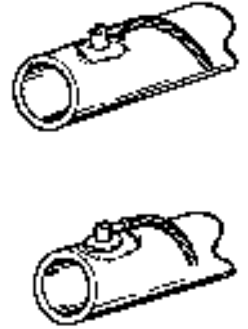

Sample Application	Cable Cross Section mm ²	Connection Reference Code	European Item No	Typical No. of Welds per Kit	Unit Weight (kg)
Cathodic Protection Kit	16	CAHAAW3	167260	20	5,760
Cathodic Protection Kit	25	CAHAAY1	167280	20	5,700
Cathodic Protection Kit	35	CAHAAY2	167300	20	5,650
CADWELD Braze Kit	25	KIT CPB-25	167220	20	6,095
CADWELD Braze Kit	35	KIT CPB-35	167240	20	6,110

CADWELD® BRAZE KITS for CATHODIC PROTECTION

1. Horizontal Braze Kit

European Cat No	Contents		Unit Weight (kg)
545380	Graphite Crucible + cover Steel Mould with Spring + Chain Tape Flux Sparkler Isolation Kit (Mould, Resin, Accessories) 65RR10 Weld Metal Plastic Case	1 1 1 1 1 1 1 1	2.08

2. Vertical Braze Kit

European Cat No	Contents		Unit Weight (kg)
545510	Graphite Crucible + cover Steel Mould Chain with Steel Plate Flux Sparkler Fixing Kit 65RR10 Weld Metal Plastic Case	1 1 1 1 1 1 1 1	0.880

HORIZONTAL CONNECTION SS

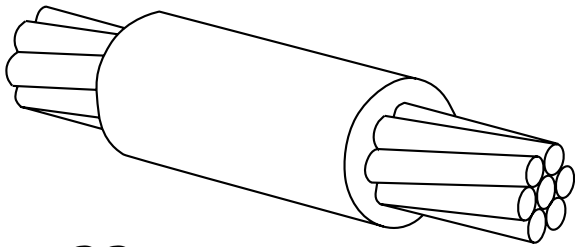

SS

HORIZONTAL SPLICE

- Splice of horizontal cables.
- Concentric stranded copper cable unless otherwise noted.
- Solid conductor may be either copper or Copperweld.
- Also available are splices of different and mixed cable sizes. For Copperweld DSA cables, contact factory.
- **Bold letter** in mould part number is the price key.

REQUIRED TOOLS

	European Cat. No.	Search Code
Handle Clamps for C Price Key Moulds	161000	L160
	for D Price Key Moulds 161020	L159
Flint Ignitor	165000	T320

SUGGESTED TOOLS

Cable Cleaning Brush	165130	T313
Slag Removal Spade	See CADWELD Classic Table	
Mould Cleaning Brush	165260	120+3/4
Cable Clamp	165020	B265
Torch Head	140160	T111

SS

CABLE SIZE (sq mm)	MOULD PART NO.	WELD METAL
10	SS C Y1	30
16	SS C Y1	32
25	SS C Y1	32
35	SS C Y2	32
50	SS C Y3	45
70	SS C Y4	65
95	SS C Y5	90
120	SS C Y6	115
150	SS C Y7	115
185	SS C Y8	150
240	SS C Y9	200
8 mm Ø	SS C W6	45
10 mm Ø	SS C W8	65

TA

HORIZONTAL TEE

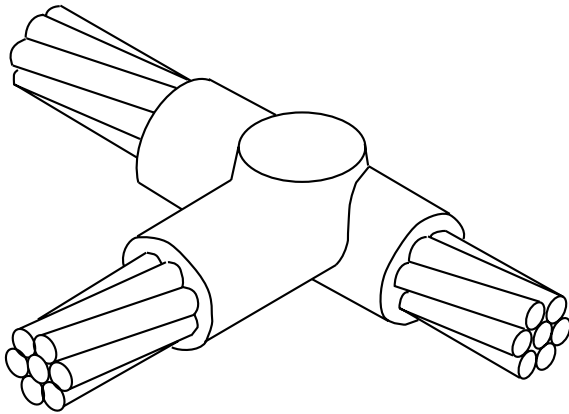

TA

HORIZONTAL TEE CONNECTIONS

- Tee of horizontal run and tap cables.
- Concentric stranded copper cable unless otherwise noted.
- Solid conductor can be either copper or Copperweld.
- **Bold letter** in mould part number is the price key.

REQUIRED TOOLS

		European Cat. No.	Search Code
Handle Clamps	for C Price Key Moulds	161000	L160
	for D Price Key Moulds	161020	L159
Flint Ignitor		165000	T320

SUGGESTED TOOLS

Cable Cleaning Brush		165030	T313
Slag Removal Spade	See CADWELD Classic Table		
Mould Cleaning Brush		165260	120+3/4
Cable Clamp		165020	B265
Torch Head		140160	T111

TA

CABLE SIZE (sq mm)		MOULD PART NO.	WELD METAL
run	tap		
16*	16*	TAC W 3W3	45
25	25	TAC Y 1Y1	45
25	16*	TAC Y 1W3	45
35	35	TAC Y 2Y2	45
35	25	TAC Y 2Y1	45
35	16*	TAC Y 2W3	45
50	50	TAC Y 3Y3	90
50	35	TAC Y 3Y2	45
50	25	TAC Y 3Y1	45
50	16*	TAC Y 3W3	45
70	70	TAC Y 4Y4	90
70	50	TAC Y 4Y3	90
70	35	TAC Y 4Y2	45
70	25	TAC Y 4Y1	45
70	16*	TAC Y 4W3	45
95	95	TAC Y 5Y5	115
95	70	TAC Y 5Y4	90
95	50	TAC Y 5Y3	90
95	35	TAC Y 5Y2	115
95	25	TAC Y 5Y1	90
95	16*	TAC Y 5W3	90

CABLE SIZE (sq mm)		MOULD PART NO.	WELD METAL
run	tap		
120	120	TAC Y 6Y6	150
120	95	TAC Y 6Y5	150
120	70	TAC Y 6Y4	90
120	50	TAC Y 6Y3	90
120	35	TAC Y 6Y2	90
120	25	TAC Y 6Y1	90
120	16	TAC Y 6W3	90
150	150	TAC Y 7Y7	200
150	120	TAC Y 7Y6	150
150	95	TAC Y 7Y5	150
150	70	TAC Y 7Y4	90
185	185	TAC Y 8Y8	200
185	150	TAC Y 8Y7	200
185	120	TAC Y 8Y6	200
240	240	TAC Y 9Y9	2 x 150
240	185	TAC Y 9Y8	200
240	150	TAC Y 9Y7	200
240	120	TAC Y 9Y6	200
8 mm Ø	8 mm Ø	TAC W 8W8	
10 mm Ø	8 mm Ø	TAC W 8W6	
10 mm Ø	10 mm Ø	TAC W 8W8	

HORIZONTAL X

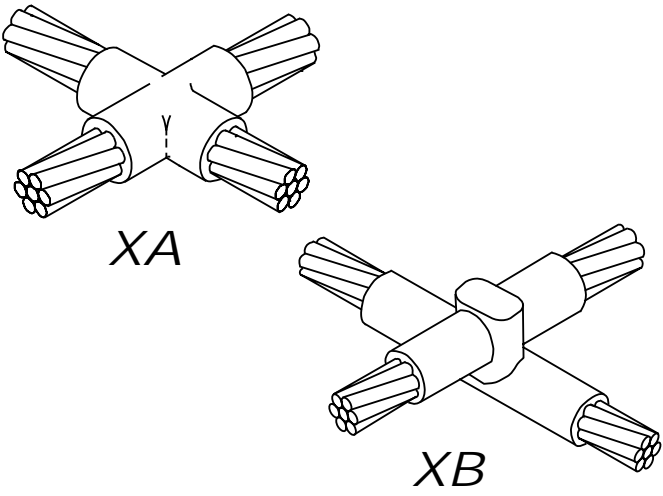
XA/XB

HORIZONTAL x CONNECTIONS

- XA – Cross of horizontal cables, tap cable cut – cables in same plane.
- XB – Cross of horizontal cables, lapped and not cut.
- Concentric stranded copper cable unless otherwise noted.
- Solid conductor may be either copper or Copperweld.
- **Bold letter** in mould part number is the price key.

REQUIRED TOOLS

	Europe.n	Search
	Cat. No	Code
Handle Clamps	for C Price Key Moulds	161000 L160
	for D Price Key Moulds	161020 L159
Flint Ignitor	165000	T320

SUGGESTED TOOLS

Cable Cleaning Brush	165030	T313
Slag Removal Spade	See CADWELD Classic Table	
Mould Cleaning Brush	165260	120+3/4
Cable Clamp	165020	B265
Torch Head	140160	T111

XA

CABLE SIZE (sq mm)		MOULD PART NO.	WELD METAL
run	tap		
25	25	XAC Y 1Y1	45
35	35	XAC Y 2Y2	65
35	25	XAC Y 2Y1	65
50	50	XAC Y 3Y3	90
50	35	XAC Y 3Y2	90
70	70	XAC Y 4Y4	115
70	50	XAC Y 4Y3	115
95	95	XAC Y 5Y5	150
95	70	XAC Y 5Y4	150
95	50	XAC Y 5Y3	115
120	120	XAC Y 6Y6	200
120	95	XAC Y 6Y5	200
120	70	XAC Y 6Y4	150
150	150	XAC Y 7Y7	250
150	120	XAC Y 7Y6	250
150	95	XAC Y 7Y5	200
150	70	XAC Y 7Y4	150
185	185	XAC Y 8Y8	2 x 150
185	150	XAC Y 8Y7	250
185	120	XAC Y 8Y6	250
240	240	XAD Y 9Y9	500
240	185	XAD Y 9Y8	2 x 200
240	150	XAD Y 9Y7	2 x 200
240	120	XAD Y 9Y6	2 x 150

XB

CABLE SIZE (sq mm)		MOULD PART NO.	WELD METAL
run	tap		
25	25	XBC Y 1Y1	65
35	35	XBC Y 2Y2	90
50	50	XB M Y3Y3	150
70	70	XB M Y4Y4	200
95	95	XB M Y5Y5	250
120	120	XB M Y6Y6	2 x 150
150	150	XB M Y7Y7	2 x 200
185	185	XB V Y8Y8	500
240	240	XB V Y9Y9	3 x 200

PT

PARALLEL HORIZONTAL

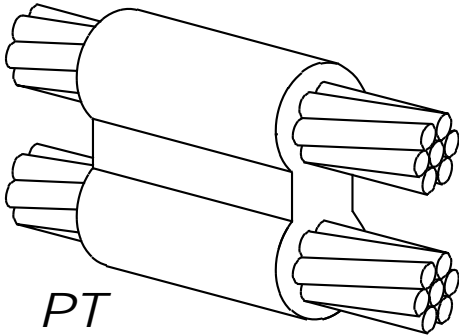
**PARALLEL HORIZONTAL CONDUCTORS**

- Parallel through connection of horizontal cables.
- Run conductor is on the bottom of Type PT moulds.
- Concentric strand copper cable unless otherwise noted.
- Solid conductor may be either copper or Copperweld.
- **Bold letter** in mould part number is the price key.

REQUIRED TOOLS

		European Cat. No.	Search Code
Handle Clamps	for C Price Key Moulds	161000	L160
	for D Price Key Moulds	161020	L159
Flint Ignitor		165000	T320

SUGGESTED TOOLS

Cable Cleaning Brush		165030	T313
Slag Removal Spade	See CADWELD Classic Table		
Mould Cleaning Brush		165260	120+3/4
Cable Clamp		165020	B265
Torch Head		140160	T111

PT

CABLE SIZE (sq mm)		MOULD PART NO.	WELD METAL
run	tap		
25	25	PT C Y1Y1	45
35	35	PT C Y2Y2	65
35	25	PT C Y2Y1	65
50	50	PT C Y3Y3	90
50	35	PT C Y3Y2	90
70	70	PT C Y4Y4	115
70	50	PT C Y4Y3	115
95	95	PT C Y5Y5	150
95	70	PT C Y5Y4	150
95	50	PT C Y5Y3	150
120	120	PT C Y6Y6	200
120	95	PT C Y6Y5	200
120	70	PT C Y6Y4	150
150	150	PT D Y7Y7	2 x 150
150	120	PT C Y7Y6	250
150	95	PT C Y7Y5	200
150	70	PT C Y7Y4	150
185	185	PT D Y8Y8	2 x 150
185	150	PT D Y8Y7	2 x 150
185	120	PT C Y8Y6	250
240	240	PT D Y9Y9	2 x 200
240	185	PT D Y9Y8	2 x 150
240	150	PT D Y9Y7	2 x 150
240	120	PT C Y9Y6	250

HORIZONTAL STEEL SURFACE HA/HS

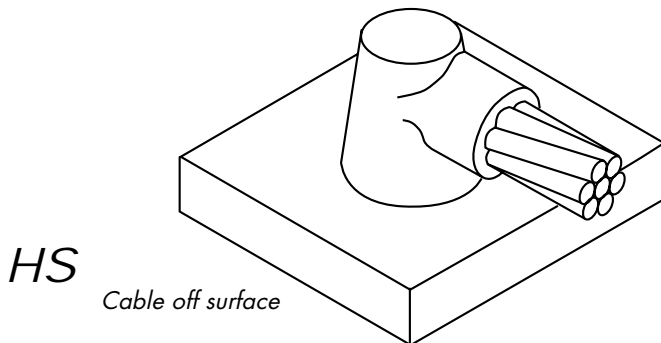
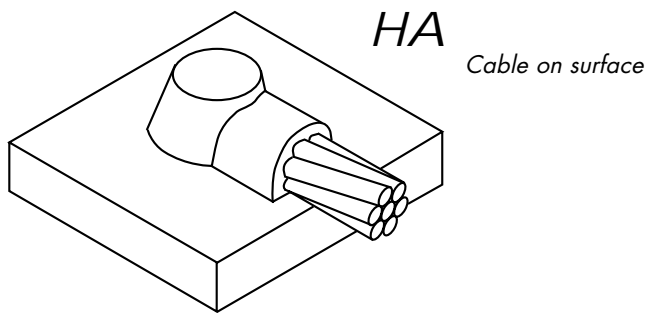

HORIZONTAL STEEL SURFACE

- Horizontal concentric copper conductor to flat steel surface or top of horizontal pipe
- CADWELD also has a complete product line for cathodic protection connections. See Bulletin CA1A.
- **A test weld should be made to check the possibility of burn-through on thin sections or thin wall pipe.**
- Concentric stranded copper cable listed.
- **Bold letter** in mould part number is the price key.

REQUIRED TOOLS

		European Cat. No.	Search Code
Handle Clamps			
Flat Surface	for C Price Key Moulds	161740	B134
	for D Price Key Moulds	1617801	B135
Pipe (curved surface)	for C Price Key Moulds		B159H
	for D Price Key Moulds		B160H
Flint Ignitor		165000	T320

SUGGESTED TOOLS

Cable Cleaning Brush		165030	T313
Slag Removal Spade	See CADWELD Classic Table		
Mould Cleaning Brush		165260	120+3/4
Cable Clamp		165020	B265
Torch Head		140160	T111

HA

CABLE SIZE (sq mm)	MOULD PART NO.	WELD METAL
25	HAA Y 1	45
35	HAA Y 2	45
50	HAA Y 3	45
70	HAA Y 4	65

HS

CABLE SIZE (sq mm)	MOLD PART NO.	WELD METAL
95	HSC Y 5	115
120	HSC Y 6	115
150	HSC Y 7	150
185	HSC Y 8	200
240	HSC Y 9	200

Cable to Steel Pipe (Types **HA** and **HS**) -
Use Flat surface mould part number with suffix.

Cable	Nominal Pipe Diameter	Suffix
35mm ² and Smaller	Less than 350mm	Nominal Diameter (mm)
	Greater than 350mm	None
50mm ² thru 120mm ²	Less than 760mm	Nominal Diameter (mm)
	Greater than 762mm	None

Example: 35mm² cable, on 100mm diameter pipe HAA-Y2-100
95mm² cable on 250mm diameter pipe HSC-Y5-250

VS

VERTICAL STEEL SURFACE

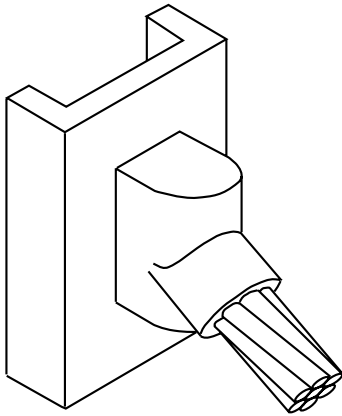

VS

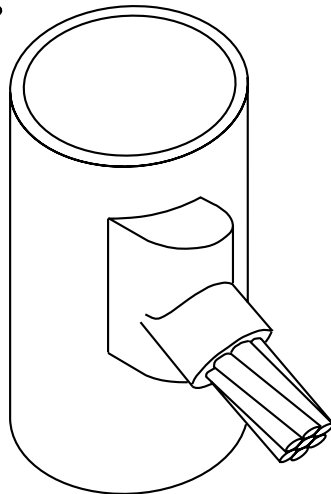
**VERTICAL STEEL SURFACE**

- Cable down at 45° to vertical steel surface including pipe.
- Cable to vertical flat steel surface; cable to side of vertical or horizontal steel pipe.
- CADWELD also has a complete product line for cathodic protection connections.
- Concentric stranded copper cable listed.
- **A test weld should be made to check the possibility of burn through on thin sections or thin wall pipe.**
- **Bold letter** in mould part number is the price key.

REQUIRED TOOLS

		European Cat. No.	Search Code
Handle Clamps	for C Price Key Moulds	161000	L160
	for D Price Key Moulds	161020	L159
Flint Ignitor		165000	T320

SUGGESTED TOOLS

Cable Cleaning Brush		165030	T313
Slag Removal Spade	See CADWELD Classic Table		
Mould Cleaning Brush		165260	120+3/4
Cable Clamp		165020	B265
Torch Head		140160	T111

VS

CABLE SIZE sq mm	MOULD PART NO.	WELD METAL
25	VSC Y 1	45
35	VSC Y 2	45
50	VSC Y 3	90
70	VSC Y 4	90
95	VSC Y 5	115
120	VSC Y 6	115
150	VSC Y 7	150
185	VSC Y 8	200
240	VSC Y 9	200

For specifications of moulds on pipe

Cable to Vertical Steel Pipe –
Use Flat surface mould part number; add **V** and suffix.

Cable	Nominal Pipe Diameter	Suffix
25mm ² thru 120mm ²	Less than 80mm 812.8mm and larger	Nominal Pipe Diameter None

Example: 70mm² to 101.6mm pipe, VSC**Y**4-102V

STUDS

HX/HV

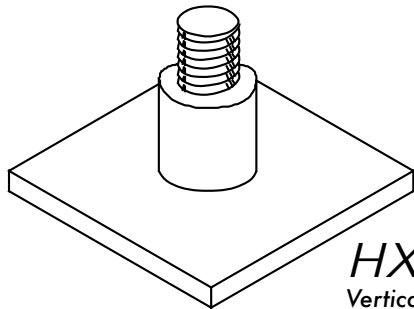

HX
Vertical stud to horizontal steel surface

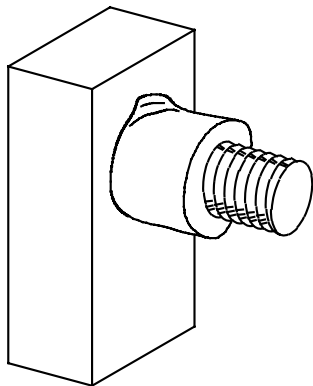

HV
Horizontal stud to horizontal steel surface

STEEL STUDS

- Connections of steel studs to steel surfaces. Studs on grounded structures provide a convenient point of attachment of temporary protective ground clamps.
- **Bold letter** in mould part number is the price key.

REQUIRED TOOLS

	European Cat. No.	Search Code
Handle Clamps for C Price Key Moulds	161000	L160
	for D Price Key Moulds 161020	L159
Flint Ignitor	165000	T320

SUGGESTED TOOLS

Mould Cleaning Brush	165260	120+3/4
Rasp	162420	T321
Torch Head	140160	T111
Mould Scraper Tool	See CADWELD Classic Table	

* Special HV kits are available for threaded bolt, threaded bar and ground terminals. Contact your CADWELD® distributor, agent or factory.

HX

THREAD DESCRIPTION	MOULD PART NO.	WELD METAL
M6	HXC-6	25
M8	HXC-8	32
M10	HXC-10	45
M12	HXC-12	65
M16	HXC-16	115

HV

THREAD DESCRIPTION	MOULD PART NO.	WELD METAL
M6	HVC-6	25
M8	HVC-8	32
M10	HVC-10	45
M12	HVC-12	65
M16	HVC-16	115
M12	HVZ-12-GPSS SBC	65

HV WELDING SET (Bolts, Washers, Nuts and Weld Metal x 20) FOR MOULDS HV6-8-10-12.

EUROPEAN CAT NO.	REFERENCE CODE	THREAD DESCRIPTION	LENGTH (mm)		Unit Weight
197470	HV-SET-M6	M6	44	1	0,880
197480	HV-SET-M8	M8	44	1	1,200
197460	HV-SET-M10	M10	44	1	1,830
197490	HV-SET-M12	M12	44	1	2,490

BA/BB

BUS BAR TAPE

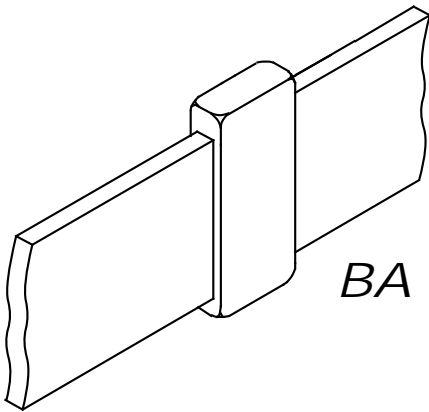

BA

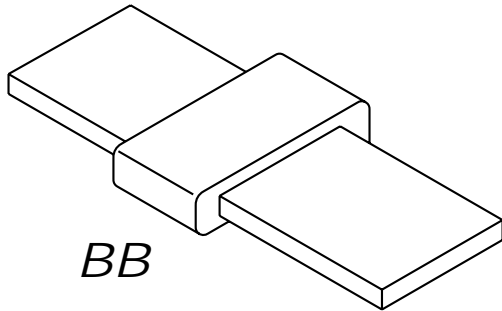

BB

COPPER BUS BAR SPLICE

- TYPE BA - Horizontal, on-edge, bus bar.
- TYPE BB - Horizontal bus bars.
- **Bold letter** in mould part number is the price key.

REQUIRED TOOLS

	European Cat. No.	Search Code
Handle Clamps	for C Price Key Moulds	161000 L160
	for D Price Key Moulds	161020 L159
Flint Ignitor	165000	T320

SUGGESTED TOOLS

Slag Removal Spade	See CADWELD Classic Table	
Mould Cleaning Brush	165260	120+3/4
Torch Head	140160	T111

BA

BUSBAR SIZE	MOULD PART #	WELD METAL
3X25	BAC C AJ	65
3X50	BAC C AM	90
4X40	BAC E AL	150
4X50	BAC E AM	115
5X40	BAC F AL	150
5X50	BAC F AM	200
6X25	BAC P AJ	115
6X50	BAC P AM	250

BB

BUSBAR SIZE	MOULD PART #	WELD METAL
3X25	BB C AJ	65
3X50	BB C AM	115
4X40	BB E AL	115
4X50	BB D EAM	200
5X40	BB F AL	150
5X50	BB D FAM	200
6X25	BB P AJ	115
6X50	BB D PAM	250

BUSBAR / TAPE KEY

Thickness (mm)	Code	Width (mm)	Code
2	BA	20	H
3	CA	25	J
3,5	DA	30	K
4	EA	35	V
5	FA	40	L
6	PA	50	M
8	GA	60	N
10	HA	80	P
		100	Q

BUS BAR TAPE BM/BQ

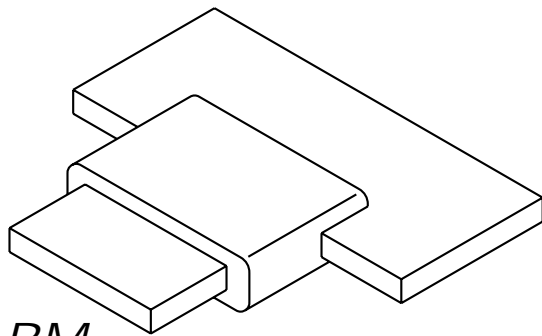

BM

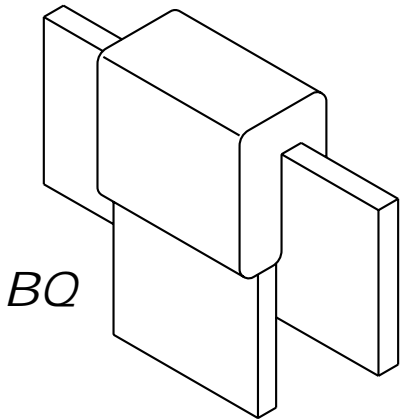

BQ

COPPER BUS BAR

- TYPE BM - Tee tap - horizontal bus bars.
- TYPE BQ - Tee tap down - horizontal, on-edge, bus bars.
- **Bold letter** in mould part number is the price key.

REQUIRED TOOLS

	European Cat. No	Search Code
Handle Clamps for C Price Key Moulds	161000	L160
	for D Price Key Moulds 161020	L159
Flint Ignitor	165000	T320

SUGGESTED TOOLS

Slag Removal Spade	See CADWELD Classic Table	
Mould Cleaning Brush	165260	120+3/4
Torch Head	140160	T111

BM

BUSBAR SIZE	MOULD PART NO.	WELD METAL
3X25	BM C CAJ	65
3X50	BM D CAM	115
4X40	BM E AL	115
4X50	BM D EAM	200
5X40	BM F FAL	150
5X50	BM D FAM	200
6X25	BM C PAJ	115
6X50	BM D PAM	250

BQ

BUSBAR SIZE	MOULD PART NO.	WELD METAL
3X25	BQ C CAJCAJ	65
3X50	BQ C CAMCAM	200
4X40	BQ E ALEAL	150
4X50	BQ E AMEAM	250
5X40	BQ F FALFAL	150
5X50	BQ F FAMFAM	200
6X25	BQ C PAJPAJ	150
6X50	BQ C PAMPAM	250

BUSBAR / TAPE KEY

Thickness (mm)	Code	Width (mm)	Code
2	BA	20	H
3	CA	25	J
3,5	DA	30	K
4	EA	35	V
5	FA	40	L
6	PA	50	M
8	GA	60	N
10	HA	80	P
		100	Q

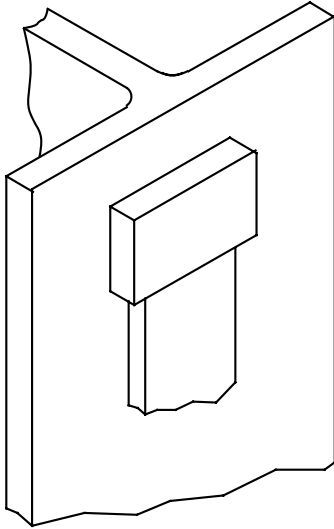
BW**BUS BAR TAPE***BW***COPPER BUS BAR TO STEEL SURFACE**

- A test weld should be made to check the possibility of burn through when intended for use on thin sections or thin wall pipe.
- **Bold letter** in mould part number is the price key.

REQUIRED TOOLS

	European Cat. No.	Search Code
Handle Clamps for C Price Key Moulds	161000	L160
for D Price Key Moulds	161020	L159
Flint Ignitor	165000	T320

SUGGESTED TOOLS

Cable Cleaning Brush	165030	T313
Slag Removal Spade	See CADWELD Classic Table	
Mould Cleaning Brush	165260	120+3/4
Torch Head	140160	T111

BW

BUSBAR SIZE	MOULD PART NO.	WELD METAL
3X25	BW C CAJ	90
3X50	BW C CAM	150
4X40	BW E EAL	200
4X50	BW E EAM	250
5X40	BW F FAL	200
5X50	BW F FAM	250
6X25	BW P PAJ	150
6X50	BW P PAM	2 x 150

BUSBAR / TAPE KEY			
Thickness (mm)	Code	Width (mm)	Code
2	BA	20	H
3	CA	25	J
3,5	DA	30	K
4	EA	35	V
5	FA	40	L
6	PA	50	M
8	GA	60	N
10	HA	80	P
		100	Q

CABLE TO BUS BAR/TAPE LJ

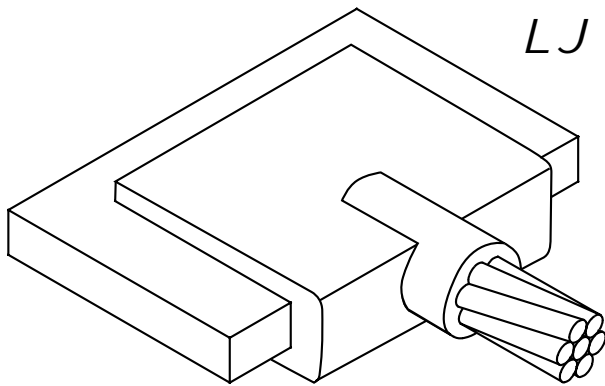

CABLE TO BUS BAR

- Tap of horizontal cable to edge of horizontal, flat bus bar.
- Concentric stranded copper cable is listed.
- The minimum distance between adjacent welds is indicated as "C" dimension.
- **Bold letter** in mould part number is the price key.

REQUIRED TOOLS

	European Cat. No.	Search Code
Handle Clamps for C Price Key Moulds	161000	L160
	for D Price Key Moulds 161020	L159
Flint Ignitor	165000	T320

SUGGESTED TOOLS

Cable Cleaning Brush	165030	T313
Slag Removal Spade	See CADWELD Classic Table	
Mould Cleaning Brush	165260	120+3/4
Torch Head	140160	T111

LJ

BUS BAR (mm)	CABLE SIZE (sq mm)	MOULD PART NO.	WELD METAL
3 x 25	35	LJ C CAJY2	45
	50	LJ C CAJY3	90
	70	LJ C CAJY4	90
4 x 40 & WIDER	35	LJ C EALY2	45
	50	LJ C EALY3	90
	70	LJ C EALY4	90
	95	LJ C EALY5	90
	120	LJ C EALY6	90
	150	LJ C EALY7	115
	185	LJ C EALY8	115
	240	LJ C EALY9	150
	5 x 40 & WIDER	35	LJ C FALY2
50		LJ C FALY3	65
70		LJ C FALY4	90
95		LJ C FALY5	90
120		LJ C FALY6	115
150		LJ C FALY7	150
185		LJ C FALY8	150
240		LJ C FALY9	200
6 x 40 & WIDER		35	LJ C PALY2
	50	LJ C PALY3	90
	70	LJ C PALY4	90
	95	LJ C PALY5	90
	120	LJ C PALY6	115
	150	LJ C PALY7	115
	185	LJ C PALY8	150
	240	LJ C PALY9	200

BUSBAR / TAPE KEY

Thickness (mm)	Code	Width (mm)	Code
2	BA	20	H
3	CA	25	J
3,5	DA	30	K
4	EA	35	V
5	FA	40	L
6	PA	50	M
8	GA	60	N
10	HA	80	P
		100	Q

LA

COPPER LUGS (Metric)

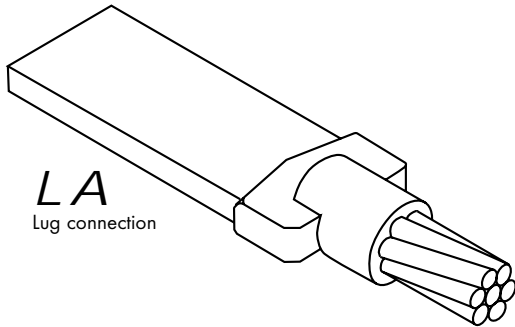

LA

CABLE SIZE (sq mm)	BUS OR LUG SIZE (mm)	MOULD PART NO.	WELD METAL
16*	2 x 20	LAC-W3-BAH	32
	2 x 25	LAC-W3-BAJ	32
	3 x 20	LAC-W3-CAH	45
	3 x 25	LAC-W3-CAJ	45
*Use Sleeve H103	3 x 20	LAC-W3-CAH	45
	3 x 25	LAC-W3-CAJ	45
	2 x 20	LAC-Y1-BAH	32
	2 x 25	LAC-Y1-BAJ	45
25	3 x 20	LAC-Y1-CAH	45
	3 x 25	LAC-Y1-CAJ	45
	4 x 25	LAC-Y1-EAJ	65
	2 x 20	LAC-Y2-BAH	32
	2 x 25	LAC-Y2-BAJ	32
35	3 x 20	LAC-Y2-CAH	45
	3 x 25	LAC-Y2-CAJ	45
	4 x 25	LAC-Y2-EAJ	65
	2 x 20	LAC-Y3-BAH	45
	2 x 25	LAC-Y3-BAJ	45
50	3 x 20	LAC-Y3-CAH	45
	3 x 25	LAC-Y3-CAJ	65
	4 x 25	LAC-Y3-EAJ	65
	3 x 25	LAC-Y4-CAJ	65
	3 x 30	LAC-Y4-CAK	90
70	4 x 25	LAC-Y4-EAJ	90
	4 x 30	LAC-Y4-EAK	90
	5 x 30	LAC-Y4-FAK	90
	3 x 25	LAC-Y5-CAJ	90
	3 x 30	LAC-Y5-CAK	90
95	4 x 25	LAC-Y5-EAJ	90
	4 x 30	LAC-Y5-EAK	115
	5 x 30	LAC-Y5-FAK	115
	3 x 25	LAC-Y6-CAJ	115
	3 x 30	LAC-Y6-CAK	115
120	4 x 25	LAC-Y6-EAJ	115
	4 x 30	LAC-Y6-EAK	115
	5 x 30	LAC-Y6-FAK	115

COPPER LUGS (METRIC)

- Lugs and connections for equipment and structures. Ideal for power utility applications.
- Concentric stranded copper cable is listed.
- **Bold letter** in mould part number is the price key.

REQUIRED TOOLS

	European Cat. No.	Search Code
Handle Clamps for C Price Key Moulds	161000	L160
	for D Price Key Moulds 161020	L159
Flint Ignitor	165000	T320
Cable Cleaning Brush	165040	T313
	165130	T314

SUGGESTED TOOLS

Mould Cleaning Brush	165260	120+3/4
Rasp	162420	T321
Torch Head	140160	T111
Mould Scraper Tool	See CADWELD Classic Table	

BUSBAR / TAPE KEY

Thickness (mm)	Code	Width (mm)	Code
2	BA	20	H
3	CA	25	J
3,5	DA	30	K
4	EA	35	V
5	FA	40	L
6	PA	50	M
8	GA	60	N
10	HA	80	P
		100	Q

PRE-DRILLED COPPER LUGS (Metric) LA

LA

Lug connection

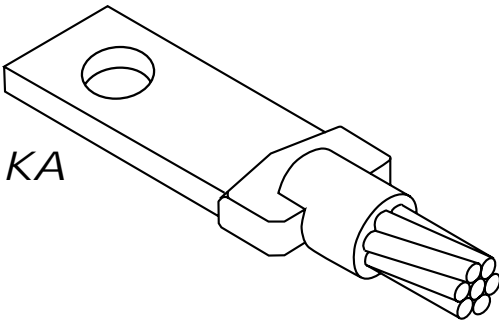

KA

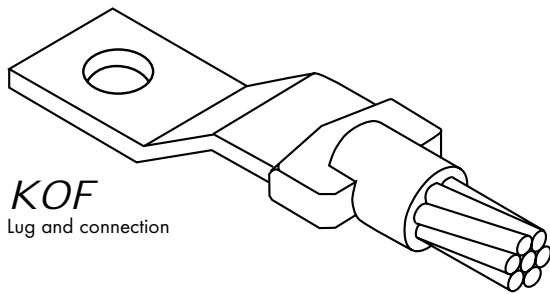

KOF

Lug and connection

PRE-DRILLED COPPER LUGS (METRIC)

- Lugs and connections for equipment and structures. Ideal for power utility applications.
- Concentric stranded copper cable is listed.
- **Bold letter** in mould part number is the price key.

REQUIRED TOOLS

	European Cat. No.	Search Code
Handle Clamps for C Price Key Moulds	161000	L160
	161020	L159
Flint Ignitor	165000	T320
Cable Cleaning Brush	165040	T313
	165130	T314

SUGGESTED TOOLS

Mould Cleaning Brush	165260	120+3/4
Rasp	162420	T321
Torch Head	140160	T111
Mould Scraper Tool	See CADWELD Classic Table	

LA

CABLE SIZE (sq mm)	BUS OR LUG SIZE (mm)	MOULD PART NO.	WELD METAL
25	2 x 20 x 45	LAC Y1 -KA101	32
	2 x 25 x 50	LAC Y1 -KA102	32
	3 x 25 x 50	LAC Y1 -KA103	32
35	2 x 20 x 45	LAC Y2 -KA101	32
	2 x 25 x 50	LAC Y2 -KA102	32
	3 x 25 x 50	LAC Y2 -KA103	32
50	2 x 20 x 45	LAC Y2 -KA101	32
	2 x 25 x 50	LAC Y2 -KA102	32
	3 x 25 x 50	LAC Y2 -KA103	32

KA

LUG TYPE	"A"	"B"	"C"	"D"	"E"
KA-101	2	20	45	10	Ø8.5
KA-102	2	25	50	12	Ø8.5
KA-103	3	25	50	12	Ø10

CABLE SIZE (sq mm)	BUS OR LUG SIZE (mm)	MOULD PART NO.	WELD METAL
25	2 x 20 x 55	LAC Y1 -KOF101	32
	2 x 25 x 55	LAC Y1 -KOF102	45
	3 x 25 x 55	LAC Y1 -KOF103	45
35	2 x 20 x 55	LAC Y2 -KOF101	32
	2 x 25 x 55	LAC Y2 -KOF102	32
	3 x 25 x 55	LAC Y2 -KOF103	45
50	2 x 20 x 55	LAC Y2 -KOF101	32
	2 x 25 x 55	LAC Y2 -KOF102	32
	3 x 25 x 55	LAC Y2 -KOF103	45

KOF

LUG TYPE	"A"	"B"	"C"	"D"	"E"	"G"
KOF-101	2	20	55	10	Ø8.5	10
KOF-102	2	25	55	10	Ø8.5	10
KOF-103	3	25	55	10	Ø8.5	10

GL COPPER LUGS (Imperial Units)

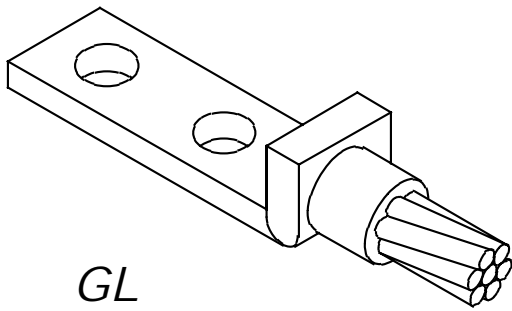

GL

COPPER LUGS (Asia Australia only)

- Lugs and connections for equipment and structures. Ideal for power applications.
- Concentric stranded copper cable is listed.
- **Bold letter** in mould part number is the price key.

REQUIRED TOOLS

		European Cat. No.	Search Code
Handle Clamps	for C Price Key Moulds	161000	L160
	for D Price Key Moulds	161020	L159
Flint Ignitor		165000	T320

SUGGESTED TOOLS

Cable Cleaning Brush		165030	T313
Slag Removal Spade	See CADWELD Classic Table		
Mould Cleaning Brush		165260	120+3/4
Cable Clamp		165020	B265
Torch Head		140160	T111

1-HOLE

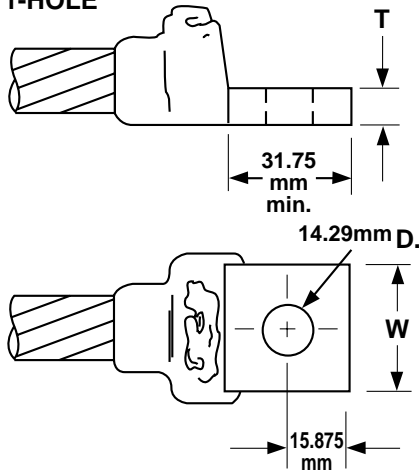

NEMA Drilled Lugs-B-121 Series

All lugs are tin plated copper.
Pat. No. 4,196,960.

GL

CABLE SIZE (sq mm)	MOULD PART NO.	WELD METAL	LUG SIZE T X W (mm)	GL LUG NUMBER	
				1 HOLE	2 HOLE
25	GL C CEY1	32	3.18 x 25.4	B-121-CE	B-122-CE
35	GL C CEY2	32	3.18 x 25.4	B-121-CE	B-122-CE
50	GL C CEY3	45	3.18 x 25.4	B-121-CE	B-122-CE
70	GL C CEY4	45	3.18 x 25.4	B-121-CE	B-122-CE
95	GL C DEY5	65	4.76 x 25.4	B-121-DE	B-122-DE
120	GL C DEY6	65	4.76 x 25.4	B-121-DE	B-122-DE
150	GL C EEY7	90	6.35 x 25.4	B-121-EE	B-122-EE
185	GL C EEY8	90	6.35 x 25.4	B-121-EE	B-122-EE
240	GL C EGY9	150	6.35 x 38.1	B-121-EG	B-122-EG

2-HOLE

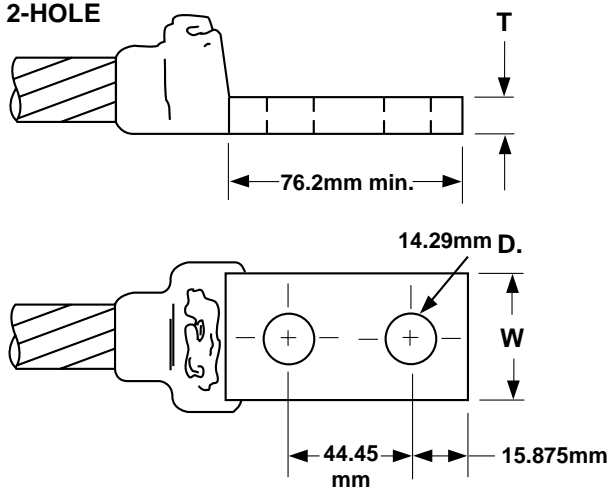

NEMA Drilled Lugs-B-122 Series

COPPER LUGS (Imperial Units)

LA

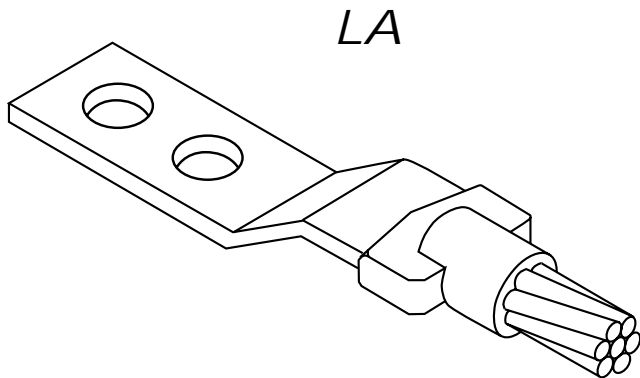

COPPER LUGS (Asia/Australia only)

- Cable to lug or bus bar connections. Can be either field fabricated from copper bus bar or factory made lugs. Ideal for power applications. Connection must be made with cable and lug horizontal.
- Concentric stranded copper cable is listed.
- **Bold letter** in mould part number is the price key.

REQUIRED TOOLS

		European Cat. No.	Search Code
Handle Clamps	for C Price Key Moulds	161000	L160
	for D Price Key Moulds	161020	L159
Flint Ignitor		165000	T320

SUGGESTED TOOLS

Cable Cleaning Brush		165030	T313
Slag Removal Spade	See CADWELD Classic Table		
Mould Cleaning Brush		165260	120+3/4
Torch Head		140160	T111

LA

CABLE SIZE (sq mm)	BUS OR LUG SIZE (mm)	MOULD PART NO.	WELD METAL
25	3.175 x 25.4	L CY 1CE	45
35	3.175 x 25.4	L CY 2CE	45
50	3.175 x 25.4	L CY 3CE	45
50	4.76 x 25.4	L CY 3DE	65
50	6.35 x 25.4	L CY 3EE	65
70	3.175 x 25.4	L CY 4CE	65
70	4.76 x 25.4	L CY 4DE	65
70	6.35 x 25.4	L CY 4EE	65
95	4.76 x 25.4	L CY 5DE	90
95	6.35 x 25.4	L CY 5EE	90
95	6.35 x 38.1	L CY 5EG	90
95	6.35 x 50.8	L CY 5EH	90
95	6.35 x 76.2	L CY 5EK	90
120	4.76 x 25.4	L CY 6DE	90
120	6.35 x 25.4	L CY 6EE	90
120	6.35 x 38.1	L CY 6EG	90
120	6.35 x 50.8	L CY 6EH	90
120	6.35 x 76.2	L CY 6EK	90

CABLE SIZE (sq mm)	BUS OR LUG SIZE (mm)	MOULD PART NO.	WELD METAL
150	6.35 x 25.4	L CY 7EE	90
150	6.35 x 38.1	L CY 7EG	90
150	6.35 x 50.8	L CY 7EH	90
150	6.35 x 76.2	L CY 7EK	90
185	6.35 x 25.4	L CY 8EE	115
185	6.35 x 38.1	L CY 8EG	115
185	6.35 x 50.8	L CY 8EH	115
185	6.35 x 76.2	L CY 8EK	115
240	6.35 x 38.1	L CY 9EG	200
240	6.35 x 50.8	L CY 9EH	200
240	9.52 x 38.1	L CY 9GG	200

See Page 49 for Lugs

LA

COPPER LUGS (Imperial Units)

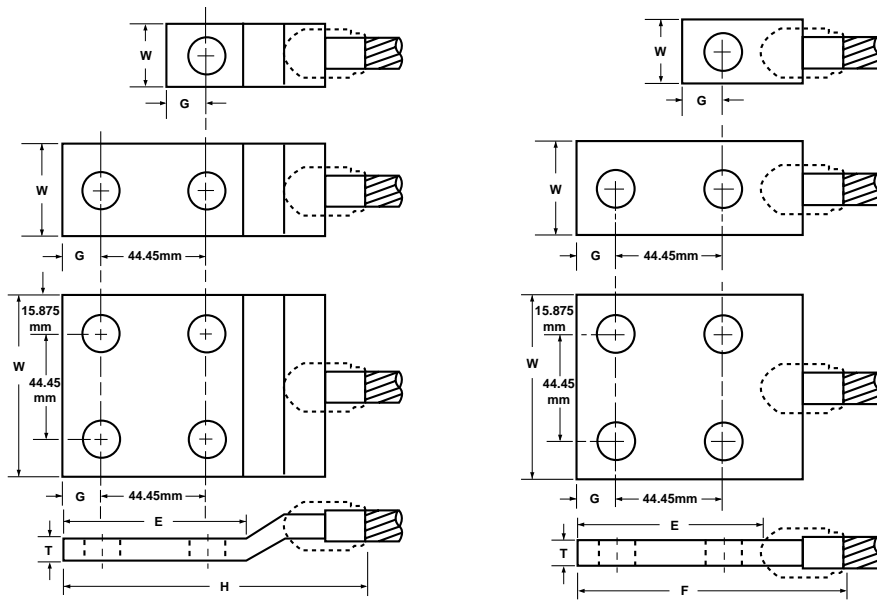

LUGS FOR TYPE LA LUG CONNECTIONS (Asia/Australia only)

NEMA lugs for Type LA connections are made from electrolytic grade copper bar stock to provide an efficient bolting surface for grounding and power applications. All listed lugs are tin plated. Telephone type lugs also available. Contact factory.

For sizes not listed or for 45° or 90° lugs, contact factory

NEMA LUGS

LUG SIZE (mm)	NUMBER of Holes	BOLT SIZE (mm)	LA LUG PART NUMBER		DIMENSIONS IN MM				SIZE		APPROX. (sq. mm)
			Straight	Offset	T	W	G	E	F*	H*	
3.175 x 25.4	1	8	B101CE	B101CEOL	3.175	25.4	12.70	19.32	60.35	79.38	80
3.175 x 25.4	2	12	B102CE	B102CEOL	3.175	25.4	15.875	76.2	114.3	133.3	80
4.76 x 25.4	1	12	B101DE	B101DEOL	4.76	25.4	14.29	28.58	73.0	92.08	120
4.76 x 25.4	2	12	B102DE	B102DEOL	4.76	25.4	15.875	76.2	120.65	139.7	120
6.35 x 25.4	1	12	B101EE	B101EEOL	6.35	25.4	15.875	28.58	76.2	92.08	150
6.35 x 25.4	2	12	B102EE	B102EEOL	6.35	25.4	15.875	76.2	123.83	142.88	150
3.175 x 38.1	1	16	B101EG	B101EGOL	6.35	38.1	19.05	38.1	76.2	104.78	240
3.175 x 38.1	2	12	B102EG	B102EGOL	6.35	38.1	15.875	76.2	123.83	142.88	240
6.35 x 50.8	2	12	B102EH	B102EHOL	6.35	50.8	15.875	76.2	133.35	152.4	325
9.525 x 38.1	1	16	B101GG	B101GGOL	9.525	38.1	19.05	38.1	95.25	120.65	350
9.525 x 38.1	2	12	B102GG	B102GGOL	9.525	38.1	15.875	76.2	146.05	177.8	350
9.525 x 50.8	1	16	B101GH	B101GHOL	9.525	50.8	25.4	54.0	111.13	142.875	500
9.525 x 50.8	2	12	B102GH	B102GHOL	9.525	50.8	15.875	76.2	146.05	177.8	500
12.7 x 50.8	2	12	B102JH	B102JHOL	12.7	50.8	15.875	76.2	146.05	177.8	600
6.35 X 76.2	4	12	B104EK	B104EKOL	6.35	76.2	15.875	76.2	139.7	158.75	500
9.525 x 76.2	4	12	B104GK	B104GKOL	9.525	76.2	15.875	76.2	152.4	177.8	700
12.7 x 76.2	4	12	B104JK	B104JKOL	12.7	76.2	15.875	76.2	158.75	184.15	800

* Approximate

See Page 48 for Moulds

CABLE TO GROUND ROD GR

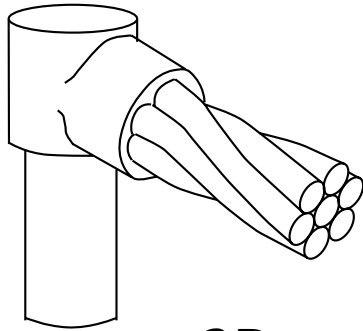

GR

CABLE TO GROUND ROD

- Single cable to top of ground rod. Concentric strand copper cable unless otherwise noted. For copper clad, galvanized, stainless clad or stainless steel ground rods.
- **Bold letter** in mould part number is the price key.

REQUIRED TOOLS

	European Cat. No	Search Code
Handle Clamps	for C Price Key Moulds	161000 L160
	for D Price Key Moulds	161020 L159
Flint Ignitor	165000	T320

SUGGESTED TOOLS

Cable Cleaning Brush	165030	T313
Slag Removal Spade	See CADWELD Classic Table	
Mould Cleaning Brush	165260	120+3/4
File	165260	T329
Cable Clamp	165020	B265
Torch Head	140160	T111

GR

GROUND ROD SIZE Dia. (mm)	CABLE SIZE (sq mm)	MOULD PART NO.	WELD METAL
12.7	25	GR C P128Y1	65
	35	GR C P128Y2	65
	50	GR C P128Y3	65
	70	GR C P128Y4	90
	95	GR C P128Y5	90
	120	GR C P128Y6	65
	150	GR C P128Y7	115
	185	GR C P128Y8	115
14.2	25	GR C P143Y1	65
	35	GR C P143Y2	90
	50	GR C P143Y3	90
	70	GR C P143Y4	90
	95	GR C P143Y5	90
	120	GR C P143Y6	90
	150	GR C P143Y7	115
	185	GR C P143Y8	150
	240	GR C P143Y9	150
17.2	25	GR C P173Y1	65
	35	GR C P173Y2	65
	50	GR C P173Y3	90
	70	GR C P173Y4	90
	95	GR C P173Y5	90
	120	GR C P173Y6	90
	150	GR C P173Y7	115
	185	GR C P173Y8	150
	240	GR C P173Y9	150

GT

CABLE TO GROUND ROD

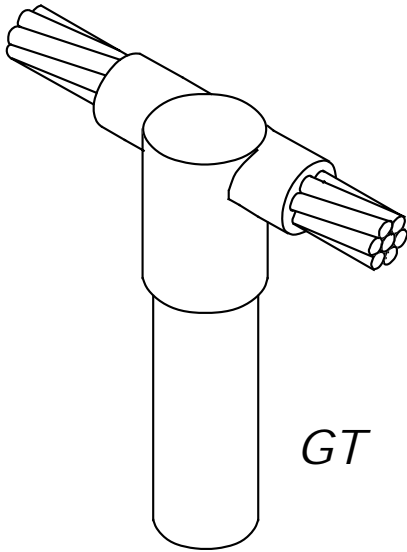

GT

GT

GROUND ROD SIZE Dia. (mm)	CABLE SIZE (sq mm)	MOULD PART NO.	WELD METAL
12.7	25	GT CP 128Y1	90
	35	GT CP 128Y2	90
	50	GT CP 128Y3	90
	70	GT CP 128Y4	90
	95	GT CP 128Y5	115
	120	GT CP 128Y6	150
	150	GT CP 128Y7	150
	185	GT CP 128Y8	200
14.2	25	GT CP 143Y1	90
	35	GT CP 143Y2	90
	50	GT CP 143Y3	90
	70	GT CP 143Y4	115
	95	GT CP 143Y5	115
	120	GT CP 143Y6	150
	150	GT CP 143Y7	200
	185	GT CP 143Y8	200
	240	GT CP 143Y9	250
17.2	25	GT CP 173Y1	90
	35	GT CP 173Y2	90
	50	GT CP 173Y3	115
	70	GT CP 173Y4	115
	95	GT CP 173Y5	115
	120	GT CP 173Y6	150
	150	GT CP 173Y7	200
	185	GT CP 173Y8	200
	240	GT CP 173Y9	250

CABLE TO GROUND ROD

- Through cable to top of ground rod. Connections are for concentric strand copper cable unless otherwise noted. For copper clad, galvanized, stainless clad or stainless steel ground rods.
- **Bold letter** in mould part number is the price key.

REQUIRED TOOLS

	European Cat. No	Search Code
Handle Clamps for C Price Key Moulds	161000	L160
for D Price Key Moulds	161020	L159
Flint Ignitor	165000	T320

SUGGESTED TOOLS

Cable Cleaning Brush	165030	T313
Slag Removal Spade	See CADWELD Classic Table	
Mould Cleaning Brush	165260	120+3/4
File	165260	T329
Torch Head	140160	T111

CABLE/TAPE TO GROUND ROD

GY

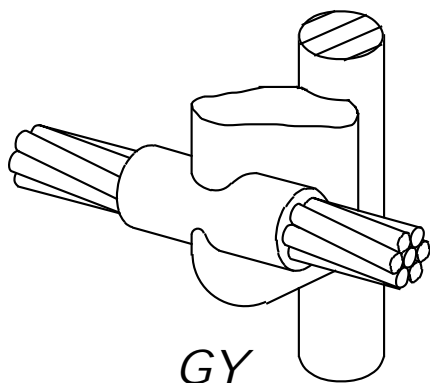

CABLE TO GROUND ROD

- Through cable to side of ground rod.
- Concentric strand copper cable unless otherwise noted.
- Ground rods can be copper clad, galvanized, stainless clad or stainless steel.
- **Bold letter** in mould part number is the price key.

REQUIRED TOOLS

		European Cat. No	Search Code
Handle Clamps	for E Price Key Moulds	161000	L160
	for J Price Key Moulds	161020	L159
Flint Ignitor		165000	T320

SUGGESTED TOOLS

Cable Cleaning Brush		165030	T313
Slag Removal Spade	See CADWELD Classic Table		
Mould Cleaning Brush		165260	120+3/4
File		165260	T329
Cable Clamp		165020	B265
Torch Head		140160	T111

GY

GROUND ROD SIZE Dia. (mm)	CABLE SIZE (sq mm)	MOULD PART NO.	WELD METAL
12.7	25	GY EP 128Y1	90
	35	GY EP 128Y2	90
	50	GY EP 128Y3	115
	70	GY EP 128Y4	115
	95	GY EP 128Y5	115
	120	GY EP 128Y6	150
	150	GY EP 128Y7	200
	185	GY EP 128Y8	200
14.2	25	GY EP 143Y1	90
	35	GY EP 143Y2	90
	50	GY EP 143Y3	115
	70	GY EP 143Y4	115
	95	GY EP 143Y5	115
	120	GY EP 143Y6	150
	150	GY EP 143Y7	200
	185	GY EP 143Y8	250
	240	GY JP 143Y9	2 x 200
17.2	25	GY EP 173Y1	90
	35	GY EP 173Y2	90
	50	GY EP 173Y3	115
	70	GY EP 173Y4	150
	95	GY EP 173Y5	150
	120	GY EP 173Y6	200
	150	GY EP 173Y7	250
	185	GY JP 173Y8	2 x 200
	240	GY JP 173Y9	2 x 200

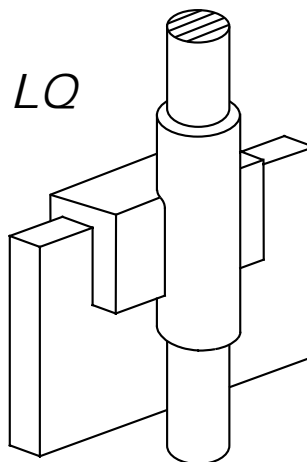

LQ

GROUND ROD SIZE Diam. (mm)	BUS BAR SIZE (mm)	MOULD PART NO.	WELD METAL
12.7	3 x 20	LQ EP -P128-CAH	90
12.7	3 x 25	LQ EP -P128-CAJ	90
14.2	3 x 20	LQ EP -P143-CAH	115
14.2	3 x 25	LQ EP -P143-CAJ	115
17.2	3 x 20	LQ EP -P173-CAH	150
17.2	3 x 25	LQ EP -P173-CAJ	150

GR/GT/NT/NX CABLE TO GROUND ROD ONE-SHOT®

Asia/Australia only

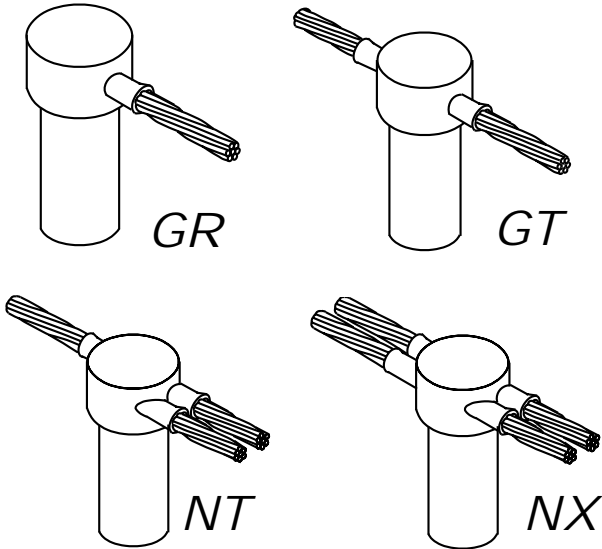

One Shot connections are available in standard packages of 12 each.

CABLE TO GROUND ROD USING CADWELD "ONE-SHOT" CONNECTIONS

For both plain or threaded copper clad and galvanized steel or stainless steel rods. The CADWELD "ONE-SHOT" case is a ceramic disposable body replacing the familiar semi-permanent graphite mould and associated Handle Clamp. Everything required is included except flint ignitor.

R.E.A. Accepted
NEC Approved

REQUIRED TOOLS

	European Cat. No.	Search Code
Flint Ignitor	165000	T320

SUGGESTED TOOLS

Cable Cleaning Brush	165030	T313
File	165260	T329
Torch Head	140160	T111

GROUND ROD SIZE Dia. (mm)	CONDUCTOR SIZE (mm ²)	CONNECTOR CATALOG NUMBER			
		TYPE GR	TYPE GT	TYPE NT	TYPE NX
12.7	8-10	GR1-141G	GT1-141G	NT1-141G	NX1-141G
	14-22	GR1-141L	GT1-141L	NT1-141L	NX1-141L
	30-38	GR1-141V	GT1-141V		
14.2	8-10	GR1-161G	GT1-161G	NT1-161G	NX1-161G
	14-22	GR1-161L	GT1-161L	NT1-161L	NX1-161L
	30-38	GR1-161V	GT1-161V	NT1-161V	NX1-161V
	50-60	GR1-162C	GT1-162C		
	70sqmm	GR1-162G			
17.2	8-10	GR1-181G	GT1-181G	NT1-181G	NX1-181G
	14-22	GR1-181L	GT1-181L	NT1-181L	NX1-181L
	30-38	GR1-181V	GT1-181V	NT1-181V	NX1-181V
	50-60	GR1-182C	GT1-182C		
	70sqmm	GR1-182G			

GROUND ROD SPLICE GB

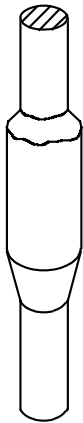

GB

GROUND ROD SPLICE

- CADWELD ground rod splices are very strong and use the proven corrosion resistant CADWELD connection.
- CADWELD ground rod splices are available for copper clad, galvanized or stainless ground rods.
- **Bold letter** in mould part number is the price key.

REQUIRED TOOLS

	European Cat. No.	Search Code
Handle Clamps for C Price Key Moulds	161000	L160
for D Price Key Moulds	161020	L159
Flint Ignitor	165000	T320
Ground Rod Splice Clamp		B120

SUGGESTED TOOLS

Cable Cleaning Brush	165030	T313
Slag Removal Spade	See CADWELD Classic Table	
Mould Cleaning Brush	165260	120+3/4
File	165260	T329
Torch Head	140160	T111

GB

GROUND ROD SIZE Dia. (mm)	MOULD PART NO.	WELD METAL
12.7	GBR-P127	200
14.2	GBR-P143	200
17.2	GBR-P172	150

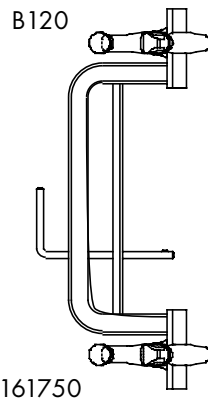

Ground Rod Splice Clamp

The B120 Ground Rod Splice Clamp must be used to support the upper rod and provide a method of correctly positioning the rods and mould while splicing the rods. (Type HDGB Connection).

RR

CABLE TO REBAR

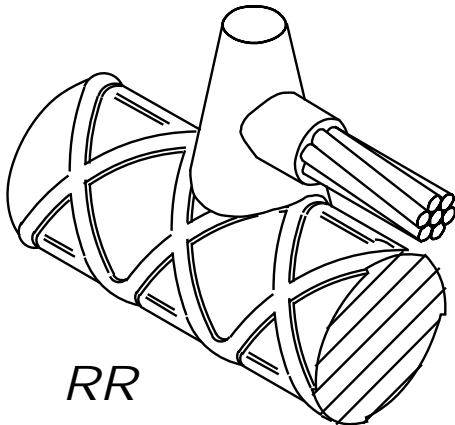

RR

CABLE TO REBAR

- Horizontal cable tap to horizontal rebar.
- Rebar material characteristics and location of weld must be considered when selecting connections to rebar.
- Concentric stranded copper cable is listed.
- **Bold letter** in mould part number is the price key.

REQUIRED TOOLS

		European Cat. No.	Search Code
Handle Clamps	for C Price Key Moulds	161000	L160
	for D Price Key Moulds	161020	L159
Flint Ignitor		165000	T320
Packing	One required for each v connection - see tables below		

SUGGESTED TOOLS

Cable Cleaning Brush		165030	T313
Slag Removal Spade	See CADWELD Classic Table		
Mould Cleaning Brush		165260	120+3/4
File		165260	T329
Torch Head		140160	T111

RR

REBAR SIZE Diam (mm)	CABLE SIZE (sq mm)	MOULD PART NO.	WELD METAL	PACKING MATERIAL
12	25	RR A R120Y1	45	B143A
	35	RR A R120Y2	45	B143A
	50	RR C R120Y3	90	B141A
	70	RR C R120Y4	90	B141A
	95	RR C R120Y5	115	B141A
16	25	RR A R160Y1	45	B143A
	35	RR A R160Y2	45	B143A
	50	RR C R160Y3	90	B141A
	70	RR C R160Y4	90	B141A
	95	RR C R160Y5	115	B141A
18	35	RR A R180Y2	45	B143B
	50	RR H R180Y3	90	B144C
	70	RR H R180Y4	90	B144C
	95	RR H R180Y5	115	B144C

REBAR SIZE Diam (mm)	CABLE SIZE (sq mm)	MOULD PART NO.	WELD METAL	PACKING MATERIAL
22	35	RR A R220Y2	45	B143A
	50	RR H R220Y3	90	B144C
	70	RR H R220Y4	90	B144C
	95	RR H R220Y5	115	B144C
25	35	RR A R250Y2	45	B143B
	50	RR H R250Y3	90	B144C
	70	RR H R250Y4	90	B144C
	95	RR H R250Y5	115	B144A
32	50	RR H R320Y3	90	B144C
	70	RR H R320Y4	90	B144C
	95	RR H R320Y5	115	B144A
36	50	RR H R360Y3	90	B144C
	70	RR H R360Y4	90	B144C
	95	RR H R360Y5	115	B144A

CABLE TO REBAR RD

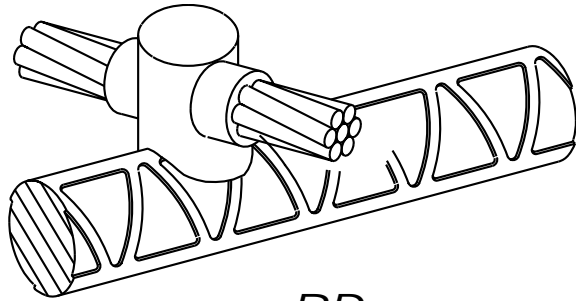

RD

CABLE TO REBAR

- X-connection horizontal cable to horizontal rebar.
- Rebar material characteristics and location of weld must be considered when selecting connections to rebar.
- Concentric stranded copper cable is listed.
- **Bold letter** in mould part number is the price key.

REQUIRED TOOLS

		European Cat. No.	Search Code
Handle Clamps	for C Price Key Moulds	161000	L160
	for D Price Key Moulds	161020	L159
Flint Ignitor		165000	T320
Packing	One required for each v connection - see tables below		

SUGGESTED TOOLS

Cable Cleaning Brush		165030	T313
Slag Removal Spade	See CADWELD Classic Table		
Mould Cleaning Brush		165260	120+3/4
File		165260	T329
Torch Head		140160	T111

RD

REBAR SIZE Diam (mm)	CABLE SIZE (sq mm)	MOULD PART NO.	WELD METAL	PACKING MATERIAL
12	25	RD C R120Y1	65	B141A
	35	RD C R120Y2	90	B141A
	50	RD M R120Y3	115	B141A
	70	RD M R120Y4	115	B141A
	95	RD M R120Y5	150	B141A
16	25	RD C R160Y1	65	B141A
	35	RD C R160Y2	90	B141A
	50	RD M R160Y3	115	B141A
	70	RD M R160Y4	115	B141A
	95	RD M R160Y5	150	B141A
18	35	RD H R180Y2	90	B144C
	50	RD H R180Y3	115	B144C
	70	RD H R180Y4	115	B144C
	95	RD H R180Y5	150	B144A

REBAR SIZE Diam (mm)	CABLE SIZE (sq mm)	MOULD PART NO.	WELD METAL	PACKING MATERIAL
22	35	RD H R220Y2	90	B144C
	50	RD H R220Y3	115	B144C
	70	RD H R220Y4	115	B144C
	95	RD H R220Y5	150	B144A
25	35	RD H R250Y2	90	B144C
	50	RD H R250Y3	115	B144C
	70	RD H R250Y4	115	B144C
	95	RD H R250Y5	150	B144A
32	50	RD H R320Y3	115	B144C
	70	RD H R320Y4	115	B144C
	95	RD H R320Y5	150	B144A
36	50	RD H R360Y3	115	B144C
	70	RD H R360Y4	115	B144C
	95	RD H R360Y5	150	B144A

RJ

CABLE TO REBAR

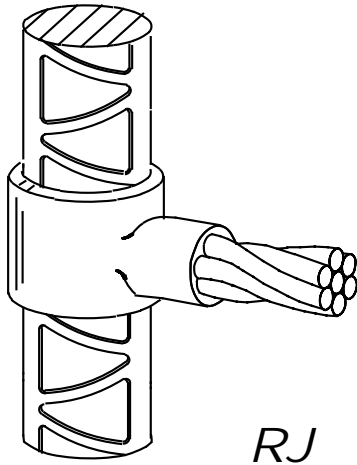
**CABLE TO REBAR**

- T-connection horizontal cable to vertical rebar.
- Rebar material characteristics and location of weld must be considered when selecting connections to rebar.
- Concentric stranded copper cable is listed.
- **Bold letter** in mould part number is the price key.

REQUIRED TOOLS

		European Cat. No.	Search Code
Handle Clamps	for C Price Key Moulds	161000	L160
	for D Price Key Moulds	161020	L159
Flint Ignitor		165000	T320
Packing	One required for each v connection - see tables below		

SUGGESTED TOOLS

Cable Cleaning Brush		165030	T313
Slag Removal Spade	See CADWELD Classic Table		
Mould Cleaning Brush		165260	120+3/4
File		165260	T329
Torch Head		140160	T111

RJ

REBAR SIZE Diam (mm)	CABLE SIZE (sq mm)	MOULD PART NO.	WELD METAL	PACKING MATERIAL
12	25	RJ C 120Y1	65	B140A
	35	RJ C 120Y2	65	B140A
	50	RJ C 120Y3	115	B140A
	70	RJ C 120Y4	115	B140A
	95	RJ C 120Y5	150	B140A
16	25	RJ C 160Y1	65	B140A
	35	RJ C 160Y2	65	B140A
	50	RJ C 160Y3	115	B140A
	70	RJ C 160Y4	115	B140A
	95	RJ C 160Y5	150	B140A
18	35	RJ C 180Y2	65	B140A
	50	RJ C 180Y3	115	B140B
	70	RJ C 180Y4	115	B140B
	95	RJ C 180Y5	150	B140B

REBAR SIZE Diam (mm)	CABLE SIZE (sq mm)	MOULD PART NO.	WELD METAL	PACKING MATERIAL
22	35	RJ E 220Y2	65	B144E
22	50	RJ E 220Y3	115	B144B
22	70	RJ E 220Y4	115	B144B
22	95	RJ E 220Y5	150	B144B
25	35	RJ E 250Y2	65	B144A
25	50	RJ E 250Y3	115	B144B
25	70	RJ E 250Y4	115	B144B
25	95	RJ E 250Y5	150	B144B
32	50	RJ E 320Y3	115	B144B
32	70	RJ E 320Y4	115	B144B
32	95	RJ E 320Y5	150	B144E
36	50	RJ E 360Y3	115	B144B
36	70	RJ E 360Y4	115	B144B
36	95	RJ E 360Y5	150	B144E

EARTH PLATES DB

TYPE DB

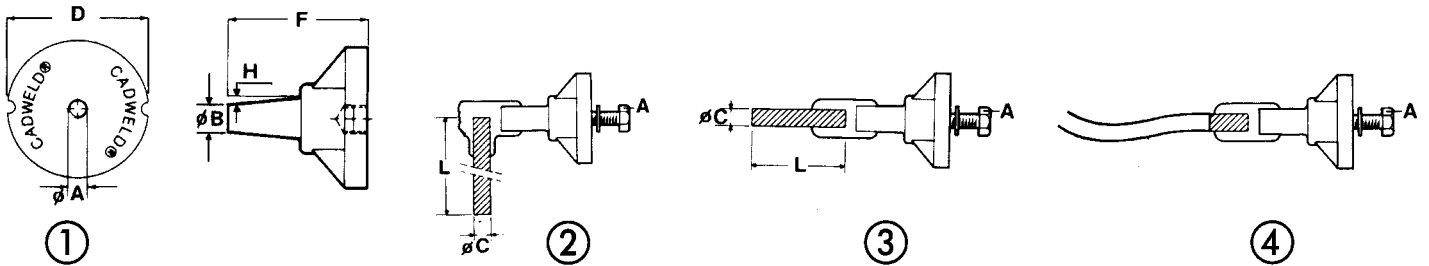
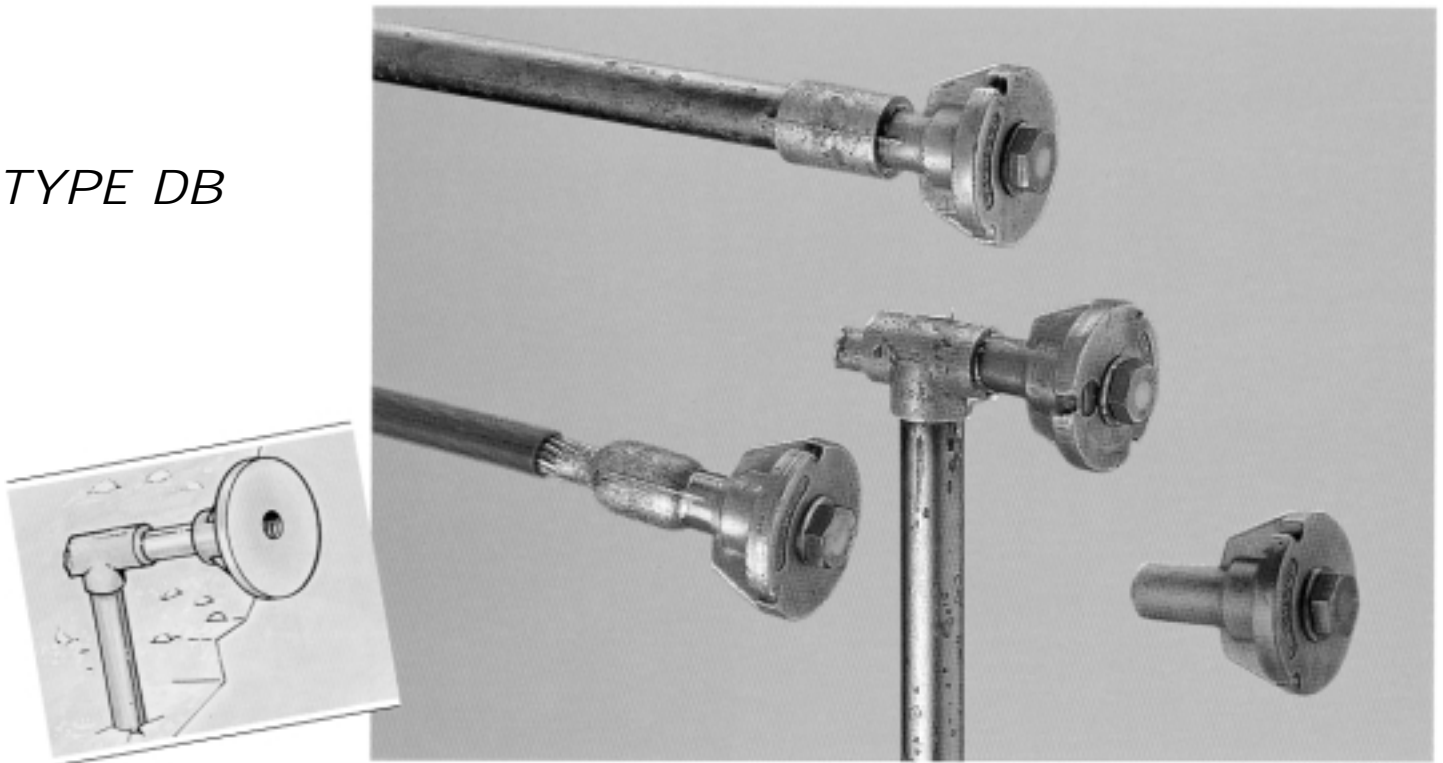

	EUROPEAN Article No.	DESCRIPTION	Ø A	Ø B (mm)	Ø C (mm)	Ø D (mm)	F (mm)	H	L (mm)
①	166090	DB-8-A	M 8	12,7	-	30	50	30'	-
	166120	DB-10-A	M10	16	-	50	55	1°	-
	166150	DB-12-A	M12	16	-	50	55	1°	-
	166180	DB-16-A	M16	16	-	50	55	1°	-
②	166100	DB-8-K	M 8	12,7	10	30	50	30'	500
	166130	DB-10-K	M10	16	19	50	55	1°	500
	166160	DB-12-K	M12	16	19	50	55	1°	500
	166190	DB-16-K	M16	16	19	50	55	1°	500
③	166110	DB-8-KS	M 8	12,7	10	30	50	30'	500
	166140	DB-10-KS	M10	16	19	50	55	1°	500
	166170	DB-12-KS	M12	16	19	50	55	1°	500
	166200	DB-16-KS	M16	16	19	50	55	1°	500
④	166480	DB-10-C5005	M10	-	50mm ²	50	55	1°	500
	166490	DB-10-C501	M10	-	50mm ²	50	55	1°	1000
	166500	DB-10-C502	M10	-	50mm ²	50	55	1°	2000

TYPE B

EARTH PLATES

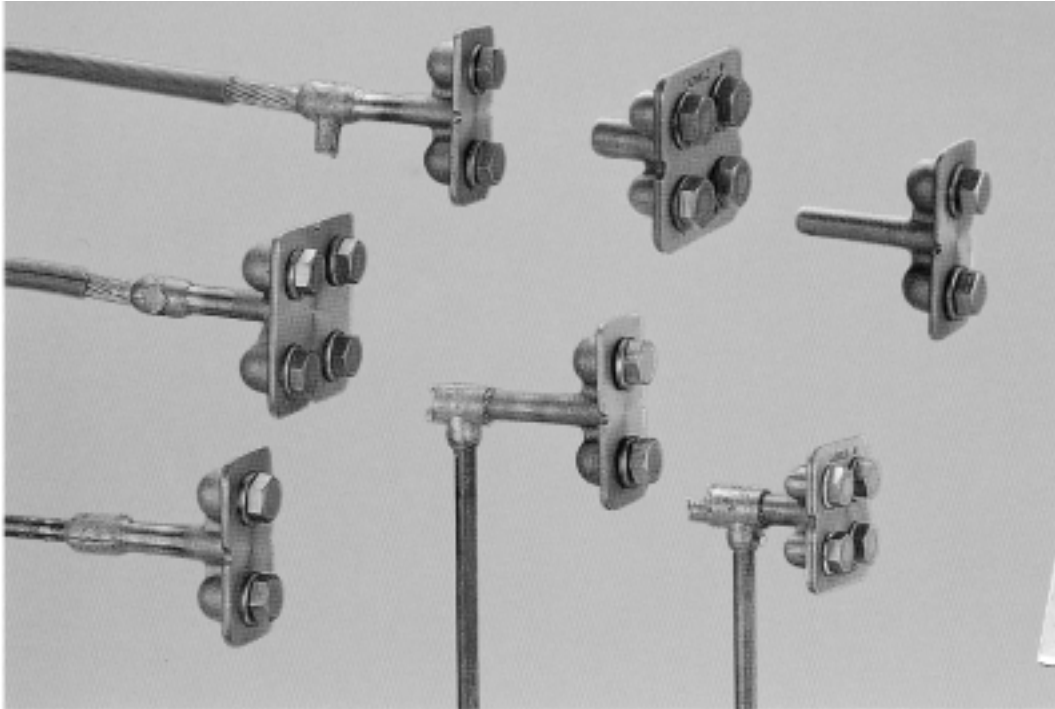

TYPE B

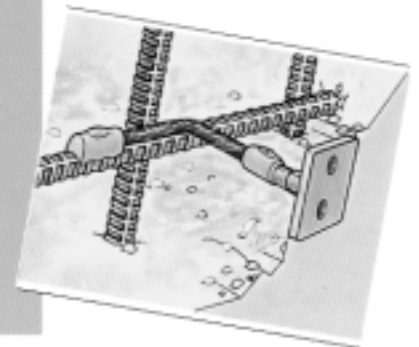

	EUROPEAN Article No.	DESCRIPTION	Ø A	Ø B (mm)	Ø C (mm)	D (mm)	F (mm)	G (mm)	H'	L (mm)
①	166000	B-161-8-A	4 x M 8	14	-	65	42	30	30	
	166030	B-161-10-B	4 x M10	14	-	65	42	30	30	
	166060	B-164-12-A	4 x M12	12,7	10	85	75	44,5	30	
②	166010	B-161-8-K	4 x M 8	14	10	65	42	30	30	500
	166040	B-161-10-KA	4 x M10	14	10	65	42	30	30	500
	166070	B-164-12-K	4 x M12	12,7	10	85	75	44,5	30	400
③	166020	B-161-8-KS	4 x M 8	14	10	65	42	30	30	500
	166050	B-161-10-KM	4 x M10	14	10	65	42	30	30	500
	166080	DB-164-12-KS	4 x M12	12,7	10	85	75	44,5	30	400
④	166510	B-161-10-C5005	4 x M 10	-	50mm ²	65	-	30	-	500
	166520	B-161-10-C501	4 x M 10	-	50mm ²	65	-	30	-	1100
	166530	B-161-10-C502	4 x M 10	-	50mm ²	65	-	30	-	2000

TYPE B161 - B164

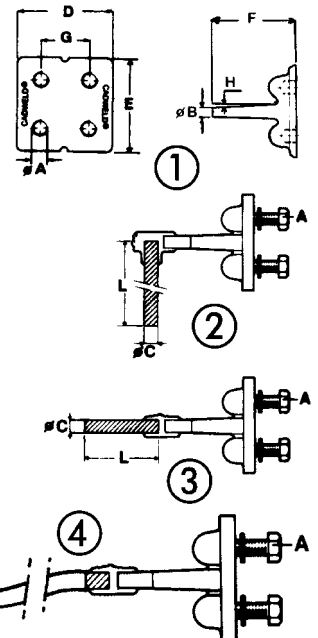

	EUROPEAN Article No.	DESCRIPTION	Ø A	Ø B (mm)	Ø C (mm)	D (mm)	E (mm)	F (mm)	G (mm)	H' (mm)	L
①	166210	B-162-12A	2 x M12	12,7	-	45	85	75	44,5	30	-
②	166220	B-162-12K	2 x M12	12,7	10	45	85	75	44,5	30	400
③	166230	B-162-12KS	2 x M12	12,7	10	45	85	75	44,5	30	400
④	166540	B-162-12-C5005	2 X M12	-	50mm ²	45	85	75	44,5	-	500
	166550	B-162-12-C501	2 X M12	-	50mm ²	45	85	75	44,5	-	1000
	166560	B-162-12-C502	2 X M12	-	50mm ²	45	85	75	44,5	-	2000

TYPE B162

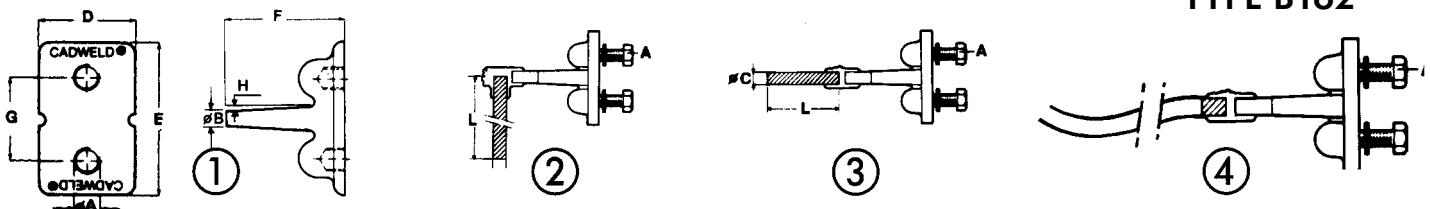

CADWELD CAST GROUND PLATES

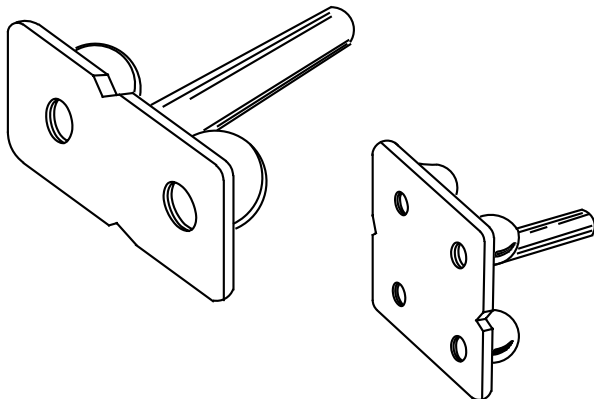

CADWELD CAST GROUND PLATES

CADWELD ground plates used in concrete structures offer convenient ground system connection points. These ground points are used for equipment, machinery and structure grounding after completion of the concrete work.

The castings are made from a copper alloy ... CADWELD ground plate connections result in current carrying capacity equal to that of the conductor or stud and cannot loosen or corrode.

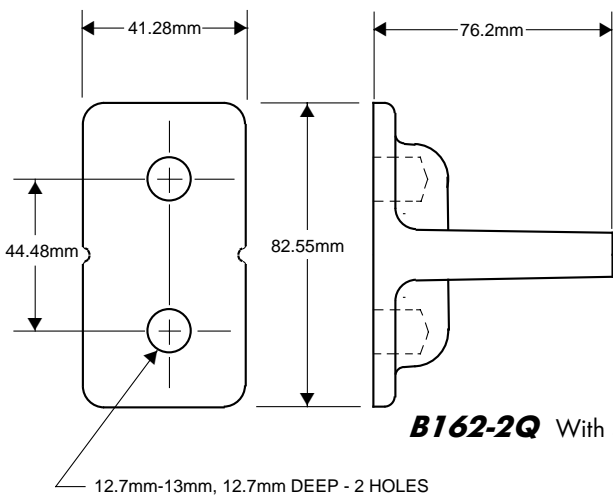

B162-2Q With 4/0 AWG Stud

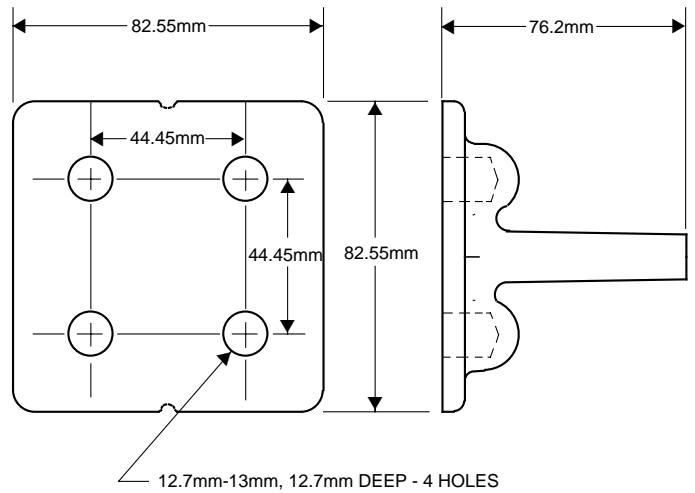

B164-2Q
With 4/0 AWG Stud
B164-3Q
With 500 kcmil Stud

Thread details: 38 UNC

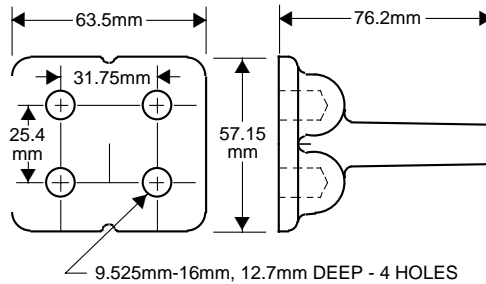

B161-2Q
With 4/0 AWG Stud
B161-3Q
With 500 kcmil Stud

CAUTION: Use only CADWELD cast ground plates. Other similar plates may be available that do not meet the strength requirements necessary. They may crack or break during installation.

Use a CADWELD Type TA or Type SS mould when connecting the CADWELD cast ground plate to the ground conductor. The cast ground plate stud size noted above fits the mould opening for a cable of the same size.

Example: Tee connection of 120mm² cable to B164-2Q (4/0 AWG stud size), use mould TAC^Y62Q.
Splice connection of 120mm² cable to B164-2Q, use mould SSC-2QY6.

AIRCRAFT GROUNDING RECEPTACLES

B-165 and B-165R

The B-165 and B-165R Grounding Receptacles are copper alloy castings intended for use in static grounding systems of aircraft refueling areas. They are easily connected to the grounding system conductor and/or ground rods with CADWELD connections. Designed for simple installation flush with the paved surface. The attachment point (19.05mm ball) is an integral part of the casting on the B-165 and is removable on the B-165R.

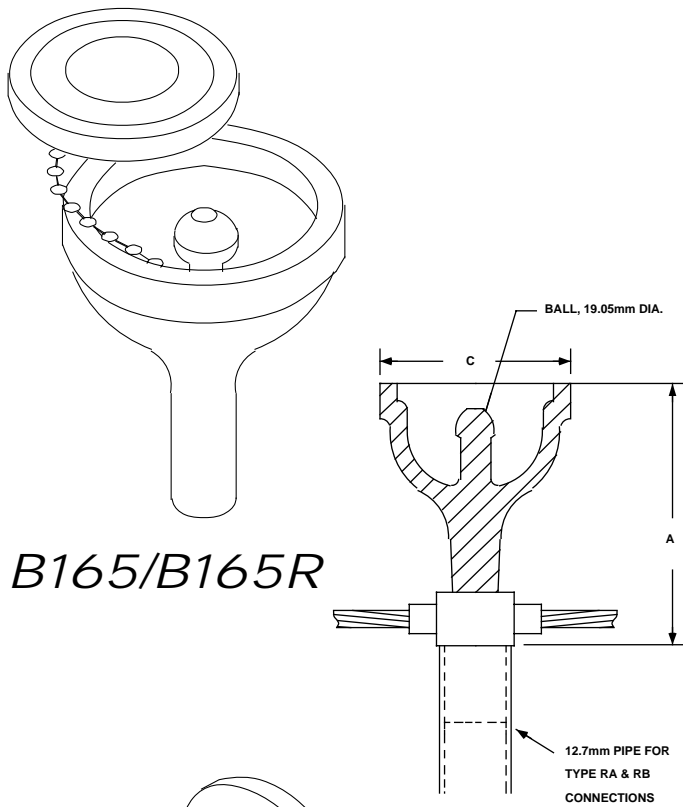

B165/B165R

RECEPTACLE	B-165 and B-165R
Depth A, Grade Level to Support.	114.3mm
Diameter C, at Grade Level	69.85mm

SPECIAL NOTE
 ERICO Aircraft Static Grounding Clamp B2617A can be used to connect to B-166 and B-167

B-166 and B-167

The B-166 and B-167 Combination Tie-down and Static Grounding Receptacles are copper alloy castings. They are easily connected to the grounding system conductor with CADWELD connections. Designed for simple installation flush with the paved surface. The attachment bar (19.05mm diameter on the B-166 and 38.1mm on the B-167) is an integral part of the casting.

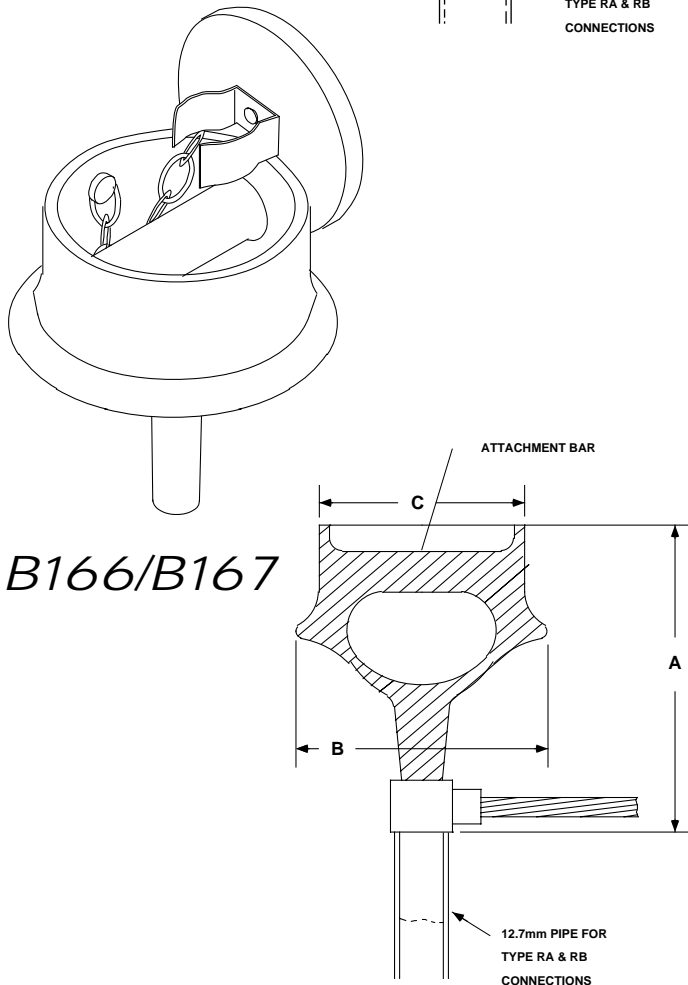

















B166/B167













RECEPTACLE	B-166	B-167
Depth A, Grade Level to Support	158.75	184.75
Diameter B, Maximum Ring Size	120.65	165.1
Diameter C, at Grade Level	8.425	120.65

For assemblies using B-166 and B-167, contact factory.

OTHER CABLE TO CABLE CONNECTIONS









The connections shown below are for use only where connections shown in this catalogue are not suitable

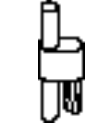

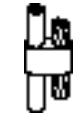







NAME	TYPE	EASE	SPLIT
Parallel dead end	PH 	3	V
	PJ 	1	V
	PK 	2	*
	PM 	3	V
	PN 	3	V
Parallel Tap	PA 	2	*
	PB 	3	V
	PC 	1	V
	PD 	3	V
	PG 	1	V
Splice	PP 	1	*
	PQ 	3	V
	PR 	2	V
	SC 	1	*
	SD 	3	V
	SE 	3	V
	SV 	3	V

NAME	TYPE	EASE	SPLIT
Tee	TC 	3	V
	TD 	3	*
	TE 	3	*
	TF 	3	V
	TL 	3	V
	TV 	3	V
X vertical (horizontal cable uncut)	XC 	3	V
X vertical (vertical cable uncut)	XD 	3	V
X vertical (neither cable cut)	XF 	3	*
X	XG 	3	*
X - 45° tap	YC 	3	V
	YD 	3	V
	YE 	3	V

OTHER CABLE TO GROUND RODS OR OTHER CONNECTIONS

The connections shown below are for use only where connections shown in this catalogue are not suitable

NAME	TYPE	EASE	SPLIT
Parallel tap	GQ 	3	V
	GS 	1	V
Parallel thru	DQ 	1	V
	GP 	3	V
	GW 	1	V
Splice	GD 	3	V
	GE 	1	V
	GF 	1	V
	GV 	1	V

NAME	TYPE	EASE	SPLIT
Tee	GG 	1	*
	GH 	3	V
	GJ 	1	*
	GK 	3	V
	GM 	2	V
	GN 	2	V
	GX 	3	V
	NB 	4	*
	NC 	1	V
	ND 	1	V
Y - 45° tap	VW 	2	V

OTHER CABLE TO STEEL OR CAST IRON

















The connections shown below are for use only where connections shown in this catalogue are not suitable















NAME	TYPE	EASE	SPLIT
Tap cast iron	VH	1	V
	VJ	1	V
	VK	1	V
	VL	1	V
	VR	1	V
Tap steel	HF	1	*
	HG	2	*
	VA	1	V
	VC	1	V
	VE	2	V
Thru cast iron	HE	1	*
Thru steel	HH	2	*
	HJ	2	*
	HK	1	V
	VX	2	V

NAME	TYPE	EASE	SPLIT
Pipe	HB	1	*
	VN	1	*
Other connections to steel	HC	1	*
	HT	1	V
	VF	1	V
	VB	2	V
	VG	1	V
	VT	1	
VV	1	V	

OTHER CABLE TO BUS BAR OR LUG

















The connections shown below are for use only where connections shown in this catalogue are not suitable













NAME	TYPE	EASE	SPLIT
EII	DN		2 V
	LX		2 *
	LY		3 *
	MA		2 *
	MB		3 *
	MC		3 *
	MD		3 *
	ME		2 *
	MF		3 *
	MG		2 V
Lug	PL		1 V
Parallel tap	LV		1 V
Parallel thru	LW		1 V
Splice	DM		2 *
	DS		2 *
	LB		1 V
	LC		3 V

NAME	TYPE	EASE	SPLIT	
Splice	LD		3 V	
	LE		1 *	
	LF		3 *	
	LG		3 V	
	LH		3 *	
	LK		2 V	
	LL		1 V	
	LM		1 V	
	LN		4 *	
	LP		2 *	
	LS		2 *	
	LT		2 *	
	LQ		2 V	
	Tee	LR		2 *

OTHER BUS BAR TO BUS BAR CONNECTIONS

The connections shown below are for use only where connections shown in this catalogue are not suitable

NAME	TYPE	EASE	SPLIT
Button-weld	TW 	1	*
	TX 	1	V
EII	DJ 	4	V
	EN 	2	*
	EQ 	4	V
	ER 	2	*
	ES 	3	*
	ET 	2	V
	EV 	3	*
	EP 	1	V
Parallel tap	BJ 	2	V
Splice	BB 	2	*
	BC 	3	V
	BD 	3	*
	BF 	2	*
	BG 	2	*
	BH 	4	V

NAME	TYPE	EASE	SPLIT
Tee	BK 	2	*
	BL 	3	*
	BN 	3	*
	BR 	2	V
	BS 	2	V
	BT 	4	*
	BV 	3	*
	DE 	3	V
	EE 	3	V
	X	EA 	4
EB 		4	*
EC 		4	*
ED 		4	V

OTHER BUS BAR CONNECTIONS









OTHER REBAR CONNECTIONS









<i>NAME</i>	<i>TYPE</i>	<i>EASE</i>	<i>SPLIT</i>
Tap	BX		3 V
	BY		3 V
	CA		3 V
	CB		2 V
	CJ		2 V
	DC		3 *
	DD		3 V
	DF		2 V
	HL		1 V
	HM		1 V
	HN		1 *
Thru	CD		3 V
	CK		2 V
	CF		1 V
	CC		1 V
	CH		1 V
	CG		1 V

<i>NAME</i>	<i>TYPE</i>	<i>EASE</i>	<i>SPLIT</i>
EII	DT		2 V
Parallel tap	DR		2 V
	RV		2 V
Parallel thru	RT		2 V
	RW		2 V
Splice	RE		2 V
	RF		2 V
	RG		1 V
	SF		2 V
	SR		1 V
	Tee	RH	
RK			1 *
RL			2 V
RM			2 V
RN			2 V
RP			2 V
RQ			2 V
X	XJ		1 *
	RC		1 V

CABLE TO COPPER TUBE





The connections shown below are for use only where connections shown in this catalogue are not suitable



NAME	TYPE	EASE	SPLIT
EII	DP		1 *
	MV		2 V
	MW		3 V
	MX		2 V
	MY		3 V
Splice	MH		1 V
	MJ		3 V
	MK		3 V

NAME	TYPE	EASE	SPLIT
Tee	ML		1 *
	MM		3 *
	MP		3 *
	MQ		3 *
	MR		3 *
	MS		3 *
	MT		3 *
	NA		1 *

BUS BAR TO GROUND RODS

The connections shown below are for use only where connections shown in this catalogue are not suitable

NAME	TYPE	EASE	SPLIT
EII	CL		1 V
Tee	CN		1 V
	CM		3 V
	CP		2 V

NAME	TYPE	EASE	SPLIT
Splice	CS		3 V
Tee	CQ		3 V
	CR		1 V

COPPER TUBE TO GROUND RODS





The connections shown below are for use only where connections shown in this catalogue are not suitable







NAME	TYPE	EASE	SPLIT
El	FT 	1	V

NAME	TYPE	EASE	SPLIT
Tee	FV 	1	V

COPPER TUBE TO COPPER TUBE



The connections shown below are for use only where connections shown in this catalogue are not suitable



NAME	TYPE	EASE	SPLIT
El	FK 	1	*
	FL 	3	V
	FM 	2	V
Splice	FD1 	V	
	FE 	3	V

NAME	TYPE	EASE	SPLIT
Tee	FH 	3	V
	FF 	1	*
	FG 	2	V
	FH 	3	V
	FJ 	3	V
X	XT 	4	*

COPPER TUBE TO BUS BARS OR LUGS

The connections shown below are for use only where connections shown in this catalogue are not suitable

NAME	TYPE	EASE	SPLIT
Splice	FN 	1	*
	FP 	1	V
Tee	EW 	2	V

NAME	TYPE	EASE	SPLIT
Tee	FR 	2	*
	FS 	1	V