

TA

## HORIZONTAL TEE

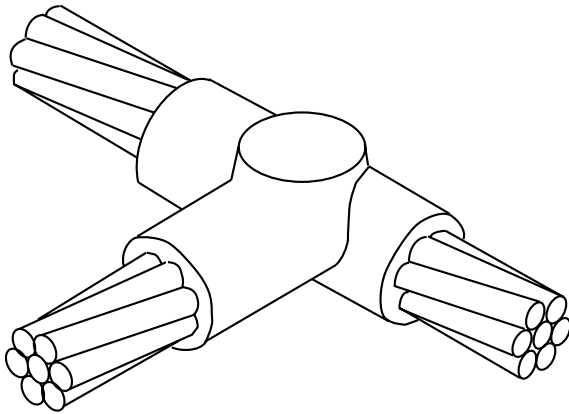

TA

**HORIZONTAL TEE CONNECTIONS**

- Tee of horizontal run and tap cables.
- Concentric stranded copper cable unless otherwise noted.
- Solid conductor can be either copper or Copperweld.
- **Bold letter** in mould part number is the price key.

**REQUIRED TOOLS**

		European Cat. No.	Search Code
<b>Handle Clamps</b>	for C Price Key Moulds	161000	L160
	for D Price Key Moulds	161020	L159
<b>Flint Ignitor</b>		165000	T320

**SUGGESTED TOOLS**

Cable Cleaning Brush		165030	T313
Slag Removal Spade	See CADWELD Classic Table		
Mould Cleaning Brush		165260	120+3/4
Cable Clamp		165020	B265
Torch Head		140160	T111

TA

CABLE SIZE (sq mm)		MOULD PART NO.	WELD METAL
run	tap		
16*	16*	TAC <b>W</b> 3W3	45
25	25	TAC <b>Y</b> 1Y1	45
25	16*	TAC <b>Y</b> 1W3	45
35	35	TAC <b>Y</b> 2Y2	45
35	25	TAC <b>Y</b> 2Y1	45
35	16*	TAC <b>Y</b> 2W3	45
50	50	TAC <b>Y</b> 3Y3	90
50	35	TAC <b>Y</b> 3Y2	45
50	25	TAC <b>Y</b> 3Y1	45
50	16*	TAC <b>Y</b> 3W3	45
70	70	TAC <b>Y</b> 4Y4	90
70	50	TAC <b>Y</b> 4Y3	90
70	35	TAC <b>Y</b> 4Y2	45
70	25	TAC <b>Y</b> 4Y1	45
70	16*	TAC <b>Y</b> 4W3	45
95	95	TAC <b>Y</b> 5Y5	115
95	70	TAC <b>Y</b> 5Y4	90
95	50	TAC <b>Y</b> 5Y3	90
95	35	TAC <b>Y</b> 5Y2	115
95	25	TAC <b>Y</b> 5Y1	90
95	16*	TAC <b>Y</b> 5W3	90

CABLE SIZE (sq mm)		MOULD PART NO.	WELD METAL
run	tap		
120	120	TAC <b>Y</b> 6Y6	150
120	95	TAC <b>Y</b> 6Y5	150
120	70	TAC <b>Y</b> 6Y4	90
120	50	TAC <b>Y</b> 6Y3	90
120	35	TAC <b>Y</b> 6Y2	90
120	25	TAC <b>Y</b> 6Y1	90
120	16	TAC <b>Y</b> 6W3	90
150	150	TAC <b>Y</b> 7Y7	200
150	120	TAC <b>Y</b> 7Y6	150
150	95	TAC <b>Y</b> 7Y5	150
150	70	TAC <b>Y</b> 7Y4	90
185	185	TAC <b>Y</b> 8Y8	200
185	150	TAC <b>Y</b> 8Y7	200
185	120	TAC <b>Y</b> 8Y6	200
240	240	TAC <b>Y</b> 9Y9	2 x 150
240	185	TAC <b>Y</b> 9Y8	200
240	150	TAC <b>Y</b> 9Y7	200
240	120	TAC <b>Y</b> 9Y6	200
8 mm Ø	8 mm Ø	TAC <b>W</b> 8W8	
10 mm Ø	8 mm Ø	TAC <b>W</b> 8W6	
10 mm Ø	10 mm Ø	TAC <b>W</b> 8W8	